

Form 390-010206

Description

The G4PB16HC I/O mounting rack accommodates up to 16 G4 I/O modules and features an extra row of terminals for field loop power connections. A header connector accepts a standard 50-pin cable, the Optomux® B1, Pamux® B5, or B100 brain board for logic connections. Barrier strips with screw terminals provide the field and mounting rack power connections.

Insert and remove modules easily and quickly without disturbing field wiring. Modules are secured to the mounting rack with a threaded captive hold-down screw. The logic supply is fused with a 1A fuse.

Part Number	Description
G4PB16HC	G4 16-Channel Rack With Header Connector Common TB

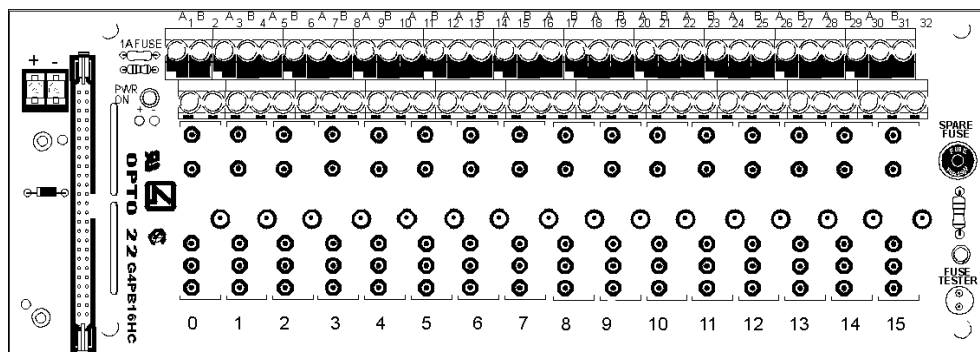

Features

- Requires minimum panel space
- Built-in fuse tester
- Spare fuse on board
- For use with Optomux B1, Pamux B5, or B100 brain boards
- Power indicator light
- Works with Opto 22 PBSA/B/C power supply
- Extra row of terminals provides field loop power connections
- UL recognized, CSA certified, CE approved
- Uses a single 5, 15, or 24 VDC power supply for control power

Form 390-010206

Specifications

Operating temperature:	0 to 70° C 95 percent relative humidity, non-condensing
Interface connector:	
Field:	Screw-type barrier strip accommodates up to 10 AWG wire
Control:	50-conductor header connector
Power:	Two-position screw terminal or Opto 22 PBSA/B/C Power Supply

Dimensions

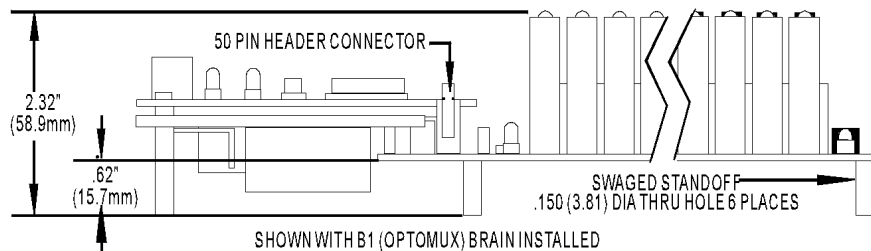
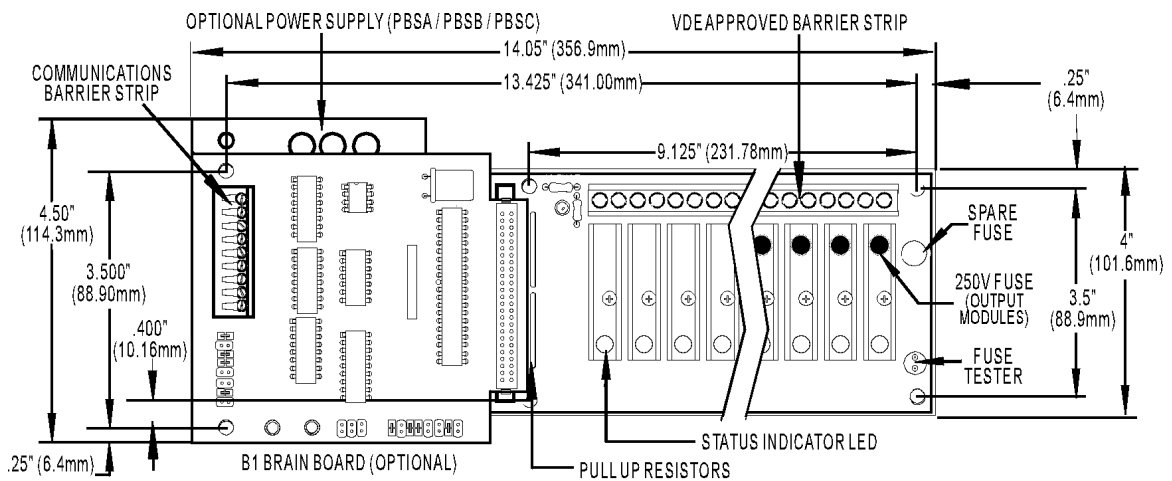

*OVERALL DIMENSION OF THE G4PB16H

Connections

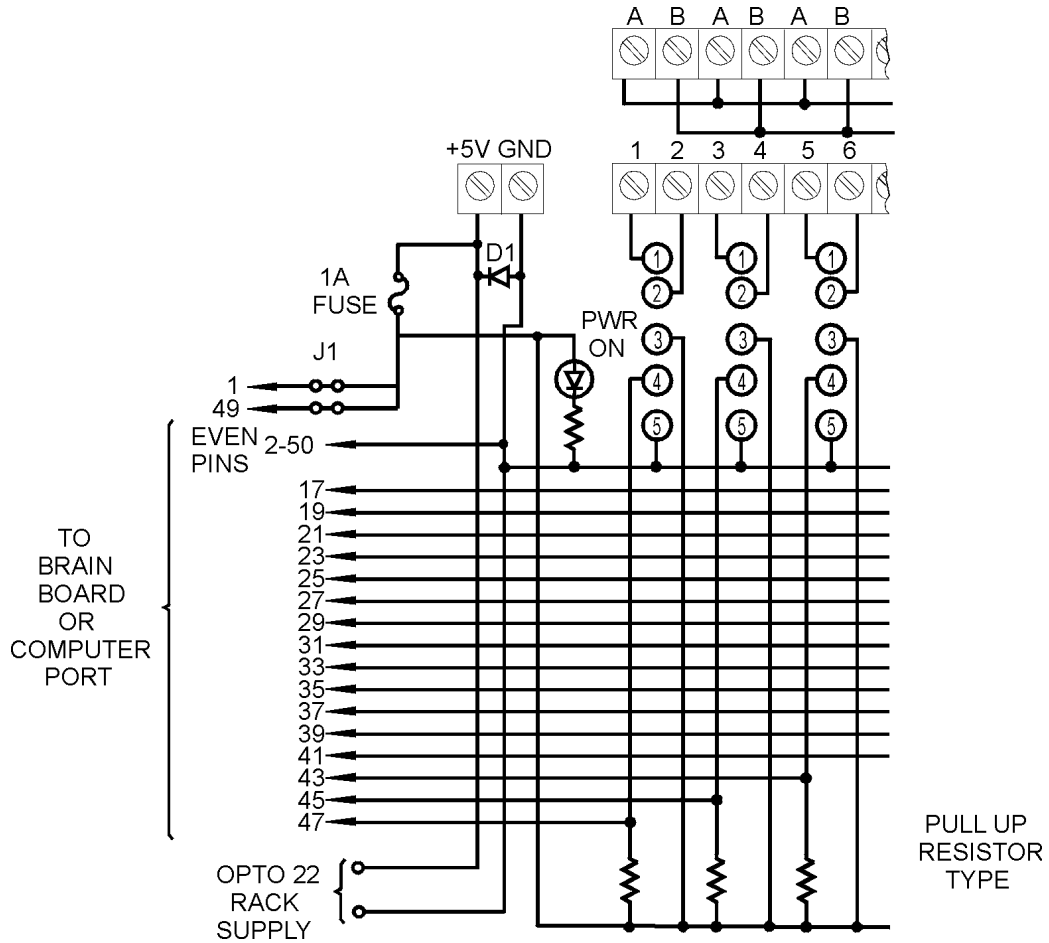

Form 390-010206

Connections (CONT.)

Notes:

1. Even pins on control connector are connected by etch to common.
2. +VCC and return connected to terminals marked +5V and GND.
3. At each module position on the field terminal strip, the lower number is always connected to pin 1 of the I/O module.
4. Use only 5 VDC logic modules when using the mounting rack with a brain board.

Module Position	Control (Header Connector)	Field (Terminal Strip)
0	47	1 and 2
1	45	3 and 4
2	43	5 and 6
3	41	7 and 8
4	39	9 and 10
5	37	11 and 12
6	35	13 and 14
7	33	15 and 16
8	31	17 and 18
9	29	19 and 20
10	27	21 and 22
11	25	23 and 24
12	23	25 and 26
13	21	27 and 28
14	19	29 and 30
15	17	31 and 32

Products

Opto 22 produces a broad array of reliable, flexible hardware and software products for industrial automation, remote monitoring, enterprise data acquisition, and machine-to-machine (M2M) applications.

SNAP Ethernet Systems

Based on the Internet Protocol (IP), SNAP Ethernet systems offer flexibility in their network connectivity and in the software applications they work with. The physical network may be a wired Ethernet network, a cellular wireless network, or a modem. A wide variety of software applications can exchange data with SNAP Ethernet systems, including:

- Opto 22's own ioProject™ suite of control and HMI software
- Manufacturing resource planning (MRP), enterprise management, and other enterprise systems
- Human-machine interfaces (HMIs)
- Databases
- Email systems
- OPC client software
- Custom applications
- Modbus/TCP software and hardware.



SNAP Ethernet system hardware consists of controllers and I/O units. Controllers provide central control and data distribution. I/O units provide local connection to sensors and equipment.

SNAP OEM Systems

Opto 22 SNAP OEM I/O systems are highly configurable, programmable processors intended for OEMs, IT professionals, and others who need to use custom software with Opto 22 SNAP I/O modules.

Linux® applications running on these systems can read and write to analog, simple digital, and serial I/O points on SNAP I/O modules using easily implemented file-based operations. Applications can be developed using several common development tools and environments, including C or C++, Java, and shell scripts.



M2M Systems

Machine-to-machine (M2M) systems connect your business computer systems to the machines, devices, and environments you want to monitor, control, or collect data from. M2M systems often use wireless cellular communications to link remote facilities to central systems over the Internet, or to provide monitoring and control capability via a cellular phone.

Opto 22's Nvio™ systems include everything you need for M2M—interface and communications hardware, data service plan, and Web portal—in one easy-to-use package. Visit nvio.opto22.com for more information.

Opto 22 Software

Opto 22's ioProject and FactoryFloor® software suites provide full-featured and cost-effective control, HMI, and OPC software to power your Opto 22 hardware. These software applications help you develop control automation solutions, build easy-to-use operator interfaces, and expand your manufacturing systems' connectivity.



Quality

In delivering hardware and software solutions for worldwide device management and control, Opto 22 retains the highest commitment to quality. We do no statistical testing; each product is made in the U.S.A. and is tested twice before leaving our 160,000 square-foot manufacturing facility in Temecula, California. That's why we can guarantee solid-state relays and optically-isolated I/O modules *for life*.

Product Support

Opto 22's Product Support Group offers comprehensive technical support for Opto 22 products. The staff of support engineers represents years of training and experience, and can assist with a variety of project implementation questions. Product support is available in English and Spanish from Monday through Friday, 7 a.m. to 5 p.m. PST.

Opto 22 Web Sites

- www.opto22.com
- nvio.opto22.com
- www.internetio.com (live Internet I/O demo)

Other Resources

- OptoInfo CDs
- Custom integration and development
- Hands-on customer training classes.



About Opto 22

Opto 22 manufactures and develops hardware and software products for industrial automation, remote monitoring, enterprise data acquisition, and machine-to-machine (M2M) applications. Using standard, commercially available Internet, networking, and computer technologies, Opto 22's input/output and control systems allow customers to monitor, control, and acquire data from all of the mechanical, electrical, and electronic assets that are key to their business operations. Opto 22's products and services support automation end users, OEMs, and information technology and operations personnel.

Founded in 1974 and with over 85 million Opto 22-connected devices deployed worldwide, the company has an established reputation for quality and reliability.