

SNAP PAC RACKS

Features

- > Compatible with all SNAP PAC brains and R-series controllers, including Wired+Wireless™ models
- > Secure mounting for SNAP I/O modules plus a SNAP brain or on-the-rack SNAP PAC controller
- > Analog, digital, and serial modules on the same rack
- > Panel or DIN-rail mounting
- > Modules snap into place
- > Factory Mutual-approved versions available



SNAP-PAC-RCK12

DESCRIPTION

SNAP PAC I/O mounting racks are designed to hold an intelligent SNAP I/O processor—a SNAP PAC EB-series or SB-series brain or a SNAP PAC R-series on-the-rack controller—and several I/O modules. Both standard wired controllers and brains and Wired+Wireless models are mounted on these racks.

Since SNAP analog, digital, and serial I/O modules all have the same footprint, customers using SNAP PAC racks can mix all these modules on the same I/O mounting rack. Field devices are wired directly to the top-mounted connectors on the modules plugged into each rack, or through breakout boards when additional wiring space is required. (See form 1756, the *SNAP TEX Cables and Breakout Boards Data Sheet*, for more information.)

SNAP PAC racks can accommodate up to 4, 8, 12, or 16 I/O modules. Part numbers ending in -FM are Factory Mutual approved.

The module and rack design allows modules to simply “snap” on the mounting rack.

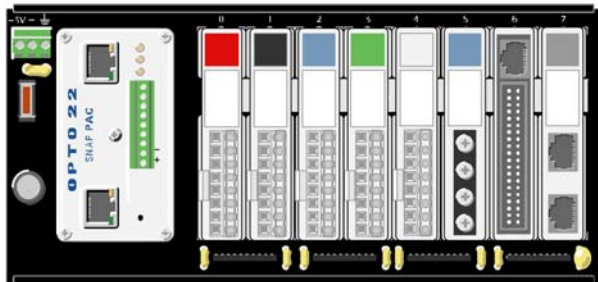

SNAP-PAC-RCK8 (8-Module Position I/O Mounting Rack)

Shown with SNAP-PAC-R1 controller and SNAP modules (all purchased separately)

SNAP PAC racks use a retention rail locking system. Install two 4-40 by 1/2-inch standard machine screws to hold each module in position.

All SNAP PAC racks offer panel mounting and the option of DIN-rail mounting. DIN-rail adapter part numbers are shown in the table below. For more information, see form 1772, the *SNAP TEX Mounting/Wiring Tools and Spare Parts Data Sheet*.

SNAP PAC racks require a 5 VDC power source. One power supply can usually power the rack, the I/O processor (controller or brain), and all modules on the rack. See form 1120, the *SNAP Power Supplies Data Sheet*, to choose a power supply.

Part Numbers

Part	Description
SNAP-PAC-RCK4	4-module SNAP PAC rack
SNAP-PAC-RCK4-FM	4-module SNAP PAC rack, Factory Mutual approved
SNAP-PAC-RCK8	8-module SNAP PAC rack
SNAP-PAC-RCK8-FM	8-module SNAP PAC rack, Factory Mutual approved
SNAP-PAC-RCK12	12-module SNAP PAC rack
SNAP-PAC-RCK12-FM	12-module SNAP PAC rack, Factory Mutual approved
SNAP-PAC-RCK16	16-module SNAP PAC rack
SNAP-PAC-RCK16-FM	16-module SNAP PAC rack, Factory Mutual approved
SNAP-FUSE7.5AB	7.5-amp fuse, 25 pack
SNAP-TEX-DRC10	SNAP rack DIN-rail adapter clip, 10-pack
SNAP-TEX-REC10W	Wide end cap for SNAP PAC racks DIN-rail assemblies, 10-pack

SPECIFICATIONS

Power ¹ Requirements	5.0 to 5.2 VDC @ 4.2 Amps max	
I/O Processor ² Compatibility	SNAP-PAC-R1	SNAP-PAC-R2-W
	SNAP-PAC-R2	SNAP-PAC-EB1-W
	SNAP-PAC-EB1	SNAP-PAC-EB2-W
	SNAP-PAC-EB2	SNAP-PAC-R1-FM
	SNAP-PAC-SB1	SNAP-PAC-R2-FM
	SNAP-PAC-SB2	SNAP-PAC-EB1-FM
	SNAP-PAC-R1-W	SNAP-PAC-EB2-FM
Replacement Fuse	SNAP-FUSE7.5AB or Littelfuse 297 07.5	
Rack Power Terminals Wire Size	22 to 14 AWG	
Operating Temperature	-20 to 70 °C	
Storage Temperature	-40 to 85 °C	
Relative Humidity	95%, non-condensing	
Agency Approvals	Non -FM models: UL, CE, RoHS, DFARS -FM models: FM, CE, ATEX, RoHS, DFARS	
Warranty	30 months from date of manufacture	

1 Power requirements shown are for a rack, a processor, and a full load of analog modules. Power requirements for SNAP serial and high-density modules are higher. See module data sheets.

2 "I/O Processor" means a SNAP PAC brain or SNAP PAC on-the-rack controller. For compatibility with legacy Opto 22 products, see form #1693, *Legacy and Current Product Comparison and Compatibility Charts*.

Module Mating Connector Pinout (female)

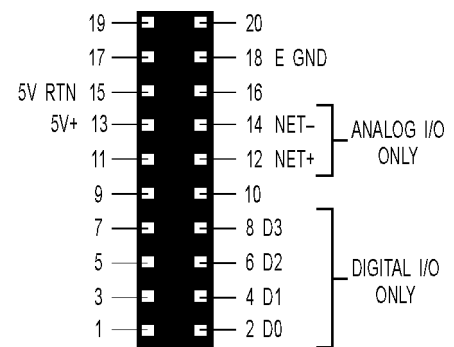

Power Schematic

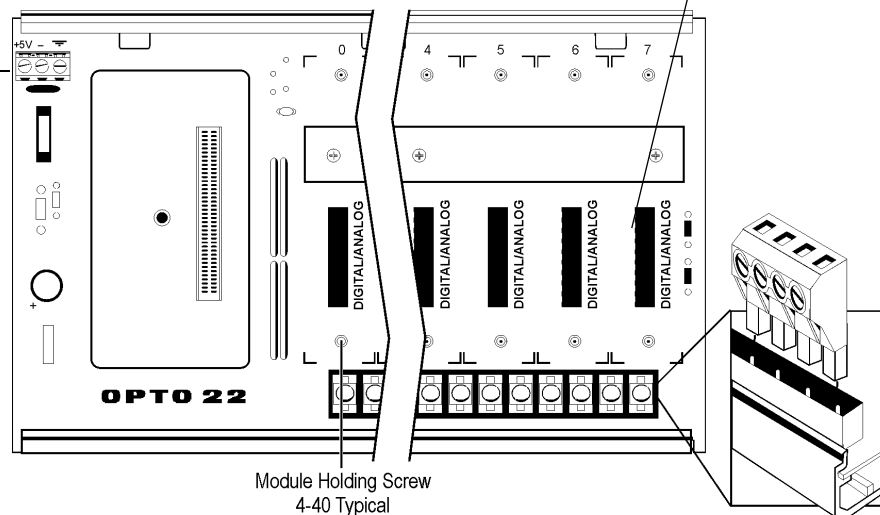
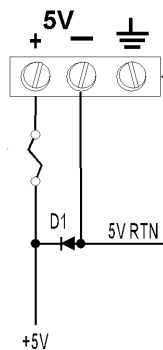

Notes on Grounding

Pin 18 E GND on each module (see diagram above right) is connected to the rack's GND. Module hold-down screws are also connected to the rack's GND.

The brain or rack-mounted controller is connected to the rack's GND through its center hold-down screw.

WARNING: EXPLOSION HAZARD. DO NOT DISCONNECT WHILE CIRCUIT IS LIVE UNLESS AREA IS KNOWN TO BE NON-HAZARDOUS.

AVERTISSEMENT: RISQUE D'EXPLOSION. NE PAS DÉBRANCHER TANT QUE LE CIRCUIT EST SOUS TENSION, À MOINS QU'IL NE S'AGISSE D'UN EMPLACEMENT NON DANGEREUX.

DIMENSIONAL DRAWINGS (CONTINUED)

Right Side View with DIN-Rail Option Installed

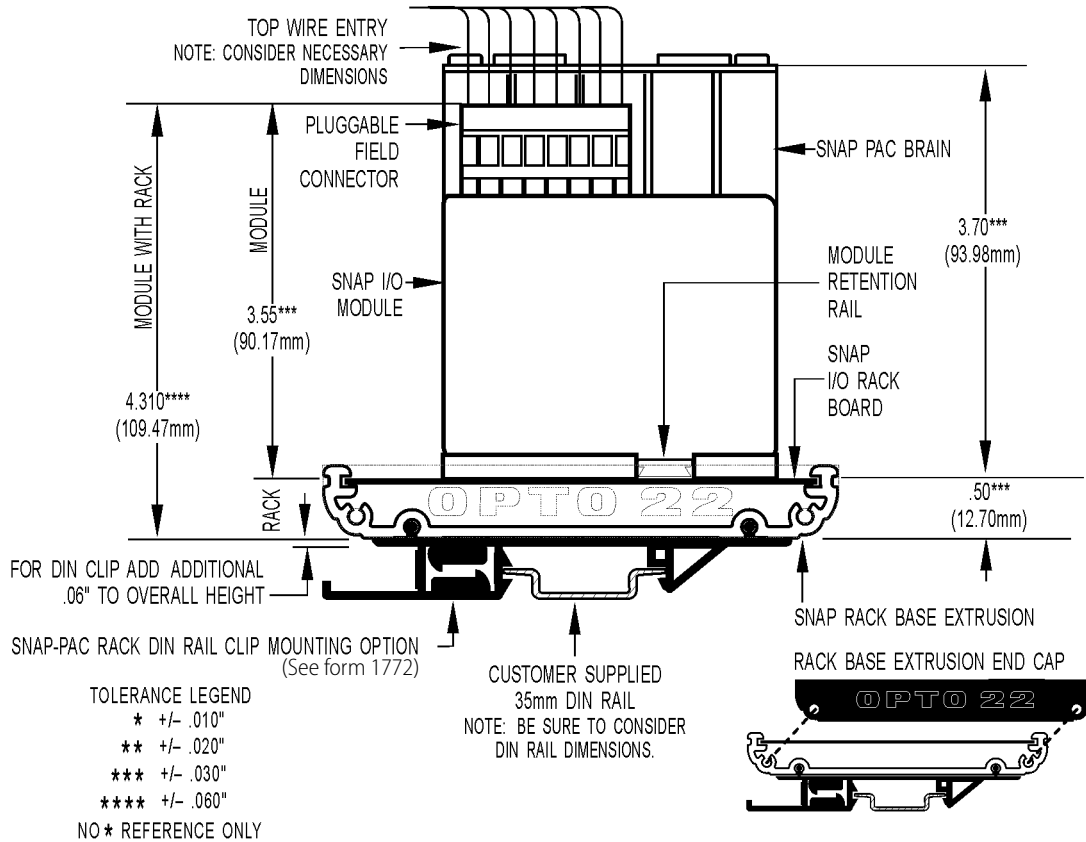

For more information on DIN-rail mounting kits, see form 1772, the *SNAP TEX Mounting/Wiring Tools and Spare Parts Data Sheet*.

MOUNTING THE EXTRUSION ONTO A PANEL

Use the following steps to mount a rack onto a panel. For DIN-rail mounting, see [page 6](#).

CAUTION: Do not let cutting fluids, cleaners, lubricants, or other chemicals contact the plastic extrusion, as they can cause cracking. If you use these chemicals before rack installation, be sure they are thoroughly cleaned off.

Preferred Method: Template

(Product on site)

1. Use SNAP PAC rack mounting extrusion as template.
2. Use the diagram below to determine required product and option clearances.

Alternate Method: Prefabrication of Panels

(No product on site)

Mounting holes are in sets of two, located on lower left and upper right with respect to a center line (CL).

1. Using the diagram below, determine CL1 mounting hole positions. (CL1 is located on the left side of all SNAP PAC rack mounting extrusions.)
2. Use the center-to-center length specification table below to determine the offset between center lines and the number of center line positions for each model.
3. Repeat the process for each center line position.

Typical Plain View of SNAP Mounting Extrusion

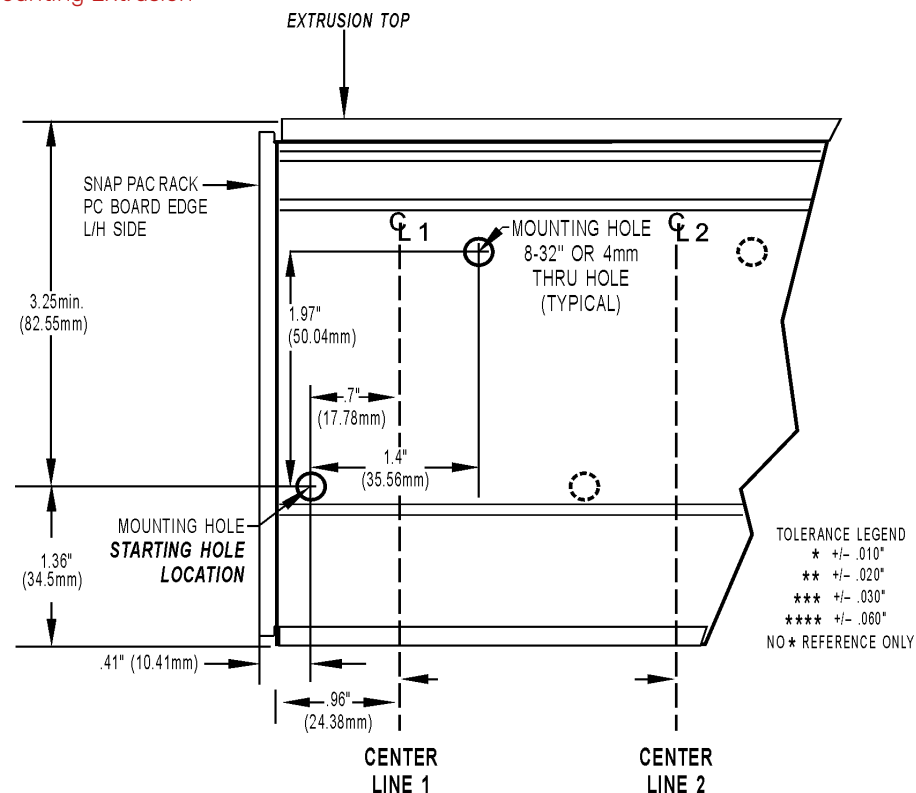

Center-to-Center Length (All Models)

Part Number	Description	Center-to-Center Length	Number of Center Positions
SNAP-PAC-RCK4 (or -FM)	4-module rack	4.02 in.	2
SNAP-PAC-RCK8 (or -FM)	8-module rack	3.51 in.	3
SNAP-PAC-RCK12 (or -FM)	12-module rack	5.01 in.	3
SNAP-PAC-RCK16 (or -FM)	16-module rack	4.34 in.	4

ASSEMBLING AND MOUNTING ON A DIN RAIL

For panel mounting, see [page 5](#).

1. (This step only for racks with three or more clips.) Slide one DIN clip to the middle position and secure with the rivet provided. For racks with four clips, add an additional middle clip.
2. Insert one edge of the circuit board into the extrusion.
3. Push down hard on the other edge to snap the board into place.
4. Attach one DIN clip to each end cap using the slots in the end caps as shown.
5. Using the screws provided, secure an end cap and DIN clip assembly to each end of the extrusion.

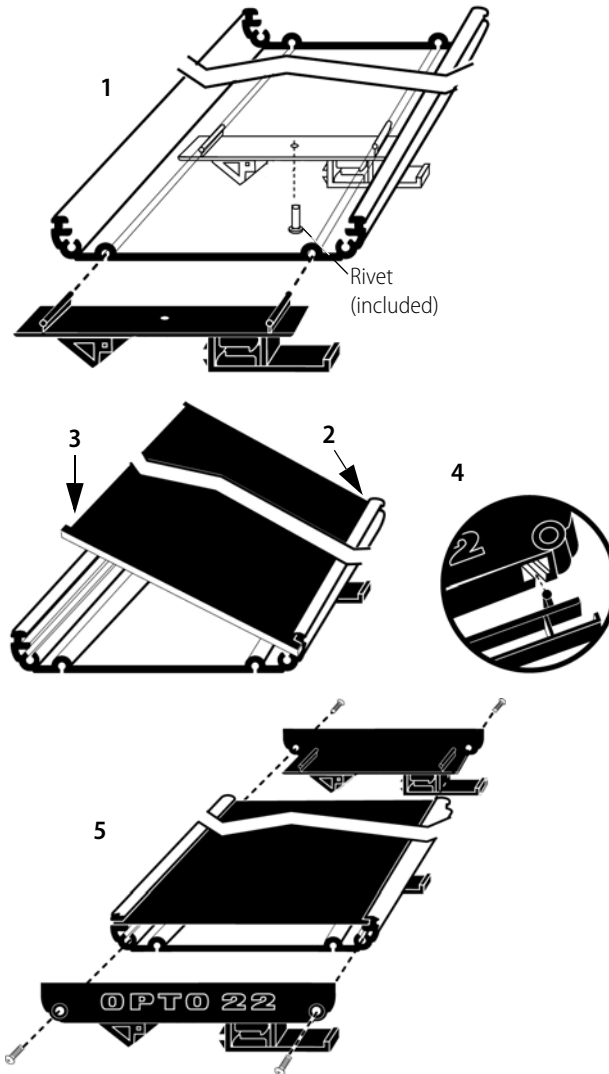

Removing the Circuit Board from the Rack Extrusion

If end caps are present, remove them. Then insert a flathead screwdriver in one of the circuit board release notches and pry up the board. Repeat in the other release notches until the board pops out of the extrusion.

Attaching the Adapter Clip to a DIN Rail

1. Hook the DIN-rail clip over the top of the DIN rail.
2. Using a screwdriver, pry open the DIN-rail clip flange at the bottom of the clip. Push the clip toward the DIN rail.
3. Snap the DIN-rail clip into place

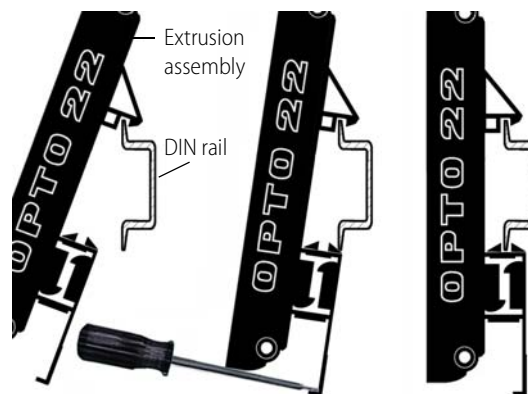

PRODUCTS

Opto 22 develops and manufactures reliable, easy-to-use, open standards-based hardware and software products used worldwide.

Industrial automation, process control, building automation, industrial refrigeration, remote monitoring, data acquisition, and Industrial Internet of Things (IIoT) applications all rely on Opto 22.



groov

Monitor and control your equipment from anywhere using your smartphone or tablet with groov. Build your own mobile app easily—just drag, drop, and tag. No programming or coding. Visit groov.com for more information and your free trial.

SNAP PAC System

Developer- and IIoT-ready, the SNAP PAC System connects physical assets to databases and applications using open standards. The SNAP PAC System consists of four integrated components:

- SNAP PAC controllers
- PAC Project™ Software Suite
- SNAP PAC brains
- SNAP I/O™

SNAP PAC Controllers

SNAP PAC programmable automation controllers handle a wide range of digital, analog, and serial functions for data collection, remote monitoring, process control, and discrete and hybrid manufacturing.

For IIoT applications and easier integration with company systems, standalone and rack-mounted SNAP PACs include a built-in HTTP/HTTPS server and **RESTful API** (application program interface). The REST API gives you secure, direct access to I/O and variable data using your choice of programming languages. No middleware, protocol converters, drivers, or gateways needed.

Based on open Ethernet and Internet Protocol (IP) standards, SNAP PACs make it easier to build or extend a system without the expense and limitations of proprietary networks and protocols.

PAC Project Software Suite

Opto 22's PAC Project Software Suite offers full-featured, cost-effective control programming, HMI (human machine interface), OPC server, and database connectivity software.

Control programming includes both easy-to-learn flowcharts and optional scripting. Commands are in plain English; variables and I/O point names are fully descriptive.

PAC Project Basic offers control and HMI tools and is free for download on our website, www.opto22.com. PAC Project Professional, available for separate purchase, adds one SoftPAC software-based controller, OptoOPCServer, OptoDataLink, options for controller redundancy or segmented networking, and support for legacy Opto 22 serial *mistic*™ I/O units.

SNAP PAC Brains

While SNAP PAC controllers provide central control and data distribution, SNAP PAC brains provide distributed intelligence for I/O processing and communications. Brains offer analog, digital, and serial functions, including thermocouple linearization, local PID loop control, watchdog, totalizing, and much more.

SNAP I/O

I/O provides the local connection to sensors and equipment. Opto 22 SNAP I/O offers 1 to 32 points of reliable I/O per module. Analog, digital, and serial modules are mixed on one mounting rack and controlled by a SNAP PAC brain or rack-mounted PAC.

QUALITY

Founded in 1974, Opto 22 has established a worldwide reputation for high-quality products. All are made in the U.S.A. at our manufacturing facility in Temecula, California.

Because we test each product twice before it leaves our factory, rather than only testing a sample of each batch, we can guarantee most solid-state relays and optically isolated I/O modules for life.



FREE PRODUCT SUPPORT

Opto 22's California-based Product Support Group offers free, comprehensive technical support for Opto 22 products from engineers with decades of training and experience. Support is available in English and Spanish by phone or email, Monday–Friday, 7 a.m. to 5 p.m. PST.

Support is always available on our website: how-to videos, user's guides, OptoKnowledgeBase, self-training guide, troubleshooting, and OptoForums. In addition, hands-on training is available for free at our Temecula, California headquarters, and you can [register online](#).

PURCHASING OPTO 22 PRODUCTS

Opto 22 products are sold directly and through a worldwide network of distributors, partners, and system integrators. For more information, contact Opto 22 headquarters at 800-321-6786 (toll-free in the U.S. and Canada) or 951-695-3000, or visit our website at www.opto22.com.