

Digital I/O Carrier Board for Raspberry Pi

Features

- Provides a GPIO interface between a Raspberry Pi® and digital I/O modules on select Opto 22 mounting racks
- Perfect for prototyping, proofs of concept, and environments in which an industrially hardened controller isn't required
- Auxiliary 40-pin connector supports HAT add-on boards using UART, SPI, or I²C
- Includes interface cable, Pi board mounting standoffs, and spare fuses for mounting racks
- Code samples available at developer.opto22.com

Description

Imagine safely and reliably sensing and switching 5-60VDC, 120 VAC, and 240 VAC loads with a Raspberry Pi. Well, now you can!

With Opto 22's Digital I/O Carrier Board for Raspberry Pi, your Pi can harness the power and performance of world-class, industrially hardened digital input/output (I/O) modules. Use your Pi to switch industrial-level electrical loads far beyond the Pi's built in 3.3 VDC GPIO pins, and monitor and control electrical loads required for real-world devices like industrial motors, pumps, and sensors.

The Carrier Board works with any model Pi with a 40-pin header connector. Just insert the board's interface cable into your Pi's GPIO connector, and snap the board onto a compatible Opto 22 rack. Use the rack's power supply to power the Pi, and then use your favorite Pi-supported programming language to read and write to up to 16 digital I/O points. (Mounting rack, power supply, and I/O modules are sold separately.)



OPTO-P1-40P

Also, the Carrier Board's auxiliary 40-pin GPIO connector lets other Pi-compatible peripherals access the Pi's unused pins.

Specifications

Interface connectors	<ul style="list-style-type: none"> • Raspberry Pi: Two 40-pin GPIO header connectors • I/O rack: One 50-conductor header connector
Operating temperature	-20 to 70 °C
Storage Temperature	-40 to 85 °C
Relative Humidity	95%, non-condensing
Agency Approvals	CE, RoHS, DFARS
Warranty	30 months from date of manufacture

Part Number

Part	Description
OPTO-P1-40P	Digital I/O Carrier Board for Raspberry Pi

Digital I/O Carrier Board for Raspberry Pi

Shown with Raspberry Pi, G4 I/O modules, mounting rack, and power supply (all sold separately).

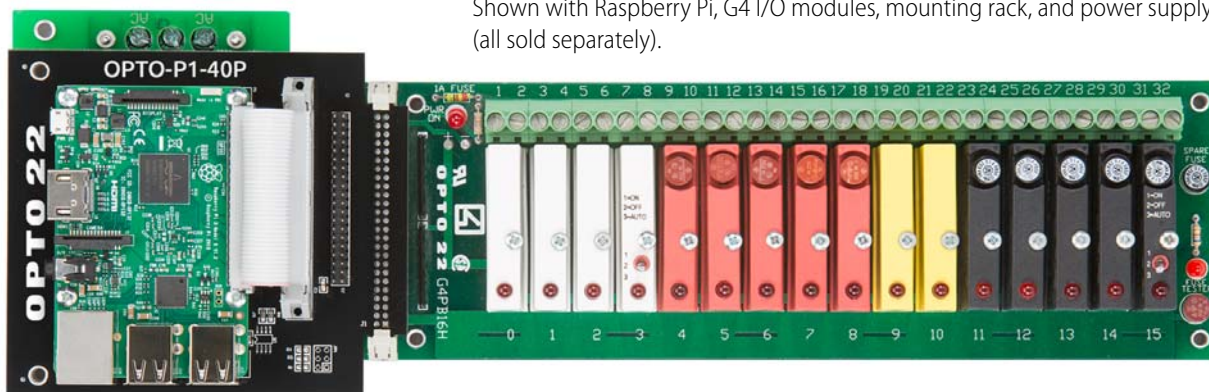

Raspberry Pi® is a trademark of the Raspberry Pi Foundation.

Digital I/O Carrier Board for Raspberry Pi

Digital I/O Carrier Board for Raspberry Pi

Shown with Raspberry Pi, SNAP I/O modules, and mounting rack (all sold separately).



Here's What You Need

- Raspberry Pi (any model with a 40-pin GPIO header connector, including Raspberry Pi Models A+ and B+, Pi 2 Model B, Pi 3 Model B, and Pi Zero)
- Digital I/O Carrier Board for Raspberry Pi
- I/O mounting rack
- I/O modules
- Power supply

G4 or SNAP?

If you don't already have I/O for your project, base your choice on the sensors and actuators you plan to use.

- Opto 22 G4 I/O has 1 point per module. Input modules are used to sense field signals. Each output module is individually fused and can switch up to 3 A. (For G4 I/O see [page 3](#).)
- Opto 22 SNAP I/O takes up less space with 4 points per module and costs less per point. Most output modules can switch up to 0.75 A per point or a total of 3 A per module. SNAP-OMR6 modules can switch up to 6 A. (For SNAP I/O, see [page 4](#).)

If you prefer to use Quad Pak or G1 I/O digital modules, the Carrier Board also supports the [PB16HQ](#), [PB4H](#), [PB8H](#) and [PB16H](#) racks.

Opto 22 I/O has been field-proven for nearly 40 years and is available worldwide. Most I/O modules carry Opto 22's Limited Lifetime Warranty. For details, see www.opto22.com.

Physical Setup

Download operating system for the Raspberry Pi.

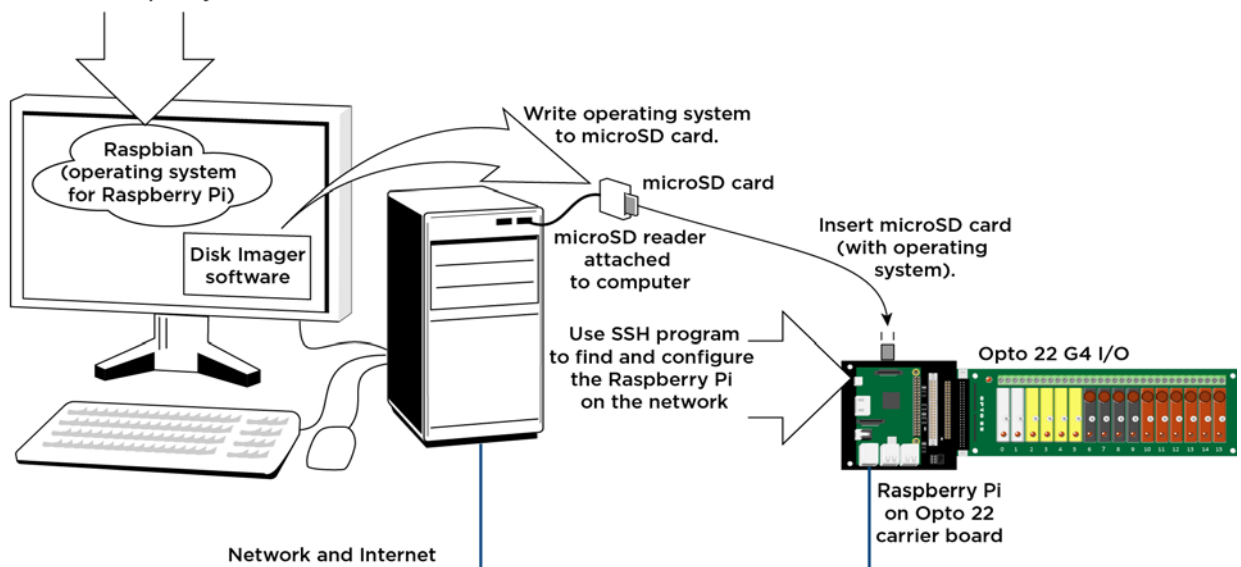

Digital I/O Carrier Board for Raspberry Pi

G4 I/O Mounting Racks

These racks can accommodate up to 10 AWG wire. The logic supply is fused with a 1 A fuse.

G4 Mounting Racks	
G4PB16H	Holds 16 I/O modules
G4PB8H	Holds 8 I/O modules

G4 I/O Modules

G4 I/O modules have a built-in LED status indicator to display the point's on/off status.

NOTE: 15 and 24 VDC logic modules are not supported.

G4 Inputs		
Model	Field Voltage	Special Features
G4IAC5	90–140 VAC/VDC	
G4IAC5A	180–280 VAC/VDC	
G4IAC5L	90–140 VAC/VDC	Low input resistance
G4IAC5MA	90–140 VAC/VDC	Diagnostic switch
G4IDC5	10–32 VDC 12–32 VAC	
G4IDC5D	2.5–28 VDC	Low voltage input
G4IDC5G	35–60 VDC/VAC	
G4IDC5MA	10–32 VDC 12–32 VAC	Diagnostic switch
G4SWIN	NA	Simulates input

G4 Outputs		
Model	Field Voltage	Special Features
G4OAC5	12–140 VAC @ 3 A	
G4OAC5A	24–280 VAC @ 3 A	
G4OAC5A5	24–280 VAC @ 3 A	Normally closed
G4OAC5MA	12–140 VAC @ 3 A	Diagnostic switch
G4OAC5AMA	24–280 VAC @ 3 A	Diagnostic switch
G4ODC5	5–60 VDC @ 3 A	
G4ODC5A	5–200 VDC @ 3 A	
G4ODC5MA	5–60 VDC	Diagnostic switch
G4SWOUT	NA	Simulates output

G4 Power Supplies

Although it's possible to power the rack and I/O modules from the Pi, Opto 22 recommends powering the components from

the rack's power supply to ensure sufficient, consistent, and reliable power to all devices connected to the Pi.

G4 Power Supplies	Input Voltage	Output Current
PBSA	120 VAC	0.5 A
PBSB	220 VAC	0.5 A
PBSC	12/24 VDC	1.5 A

Powering Peripherals

If your Pi uses USB-powered peripherals (like hard drives or WiFi dongles), you'll need a power supply that puts out more current:

- Connect a 5 V power supply rated 2.5 A to 5 A to the G4 rack's power terminals.
- Replace the G4 rack's standard 1 A fuse with the 5 A fuse (part [FUSE05B](#)—10 pack) included with the Carrier Board.

Mapping: GPIO Pins to G4 Modules

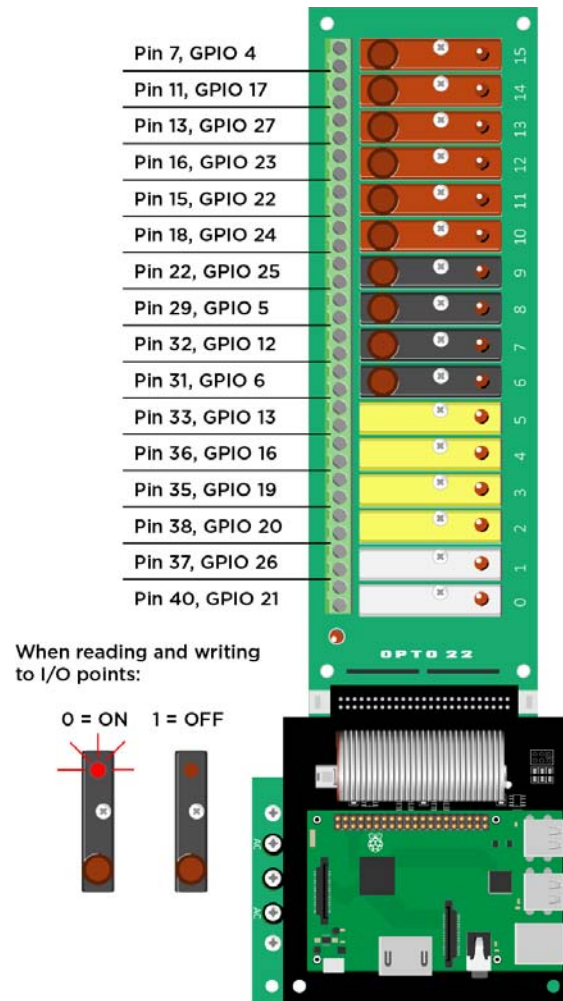

Digital I/O Carrier Board for Raspberry Pi

SNAP I/O Mounting Rack

If you've decided to use SNAP I/O modules in your Pi project, the Carrier Board works with the [SNAP-D4M](#) mounting rack. The SNAP-D4M holds 4 SNAP I/O modules (a total of 16 points). The rack ships with a 1 A fuse. If you are using USB peripherals, replace it with a 4 A fuse. For convenience, one is included with the OPTO-P1-40P Carrier Board.

SNAP I/O Modules

SNAP I/O modules have four points, and each point has an LED to indicate its status.

SNAP Inputs		
Model	Field Voltage	Special Features
SNAP-IAC5	90–140 VAC/VDC	
SNAP-IAC5A	180–280 VAC/VDC	
SNAP-IAC5MA	120 VAC/VDC	4 isolated channels, manual/auto switches
SNAP-IDC5	24 VAC/VDC	
SNAP-IDC5D	5 VDC	
SNAP-IDC5G	48 VAC/VDC	
SNAP-IDC5-HT	24 VAC/VDC	Leakage-tolerant
SNAP-IDC5MA	24 VAC/VDC	4 isolated channels, manual/auto switches
SNAP-IDC5-SW	15 VDC	Dry contact, normally open
SNAP-IDC5-SW-NC	15 VDC	Dry contact, normally closed

SNAP Outputs		
Model	Field Voltage	Special Features
SNAP-OAC5	12–250 VAC	
SNAP-OAC5-I	12–250 VAC	4 isolated channels
SNAP-OAC5MA	12–250 VAC	4 isolated channels, manual/auto switches
SNAP-ODC5SRC	5–60 VDC	Load sourcing
SNAP-ODC5SNK	5–60 VDC	Load sinking
SNAP-ODC5ASNK	5–200 VDC	Load sinking
SNAP-ODC5MA	5–60 VDC	4 isolated channels, manual/auto switches
SNAP-ODC5-I	5–60 VDC	4 isolated channels
SNAP-ODC5A-I	5–200 VDC	4 isolated channels
SNAP-OMR6-C	5–30 VDC 0–250 VAC	Mechanical Power Relay, Form C

SNAP Outputs (Continued)		
Model	Field Voltage	Special Features
SNAP-OMR6T-C	5–30 VDC 0–250 VAC	Mechanical Power Relay, Form C, with integrated transient suppression

Powering a Pi and SNAP I/O

When using the SNAP-D4M with your Pi and SNAP I/O, attach a 5 VDC @ 200 mA (max.) power supply to the rack. Powering the components from the rack's power supply ensures sufficient, consistent, and reliable power to all devices connected to the Pi.

Mapping: GPIO Pins to SNAP I/O Modules

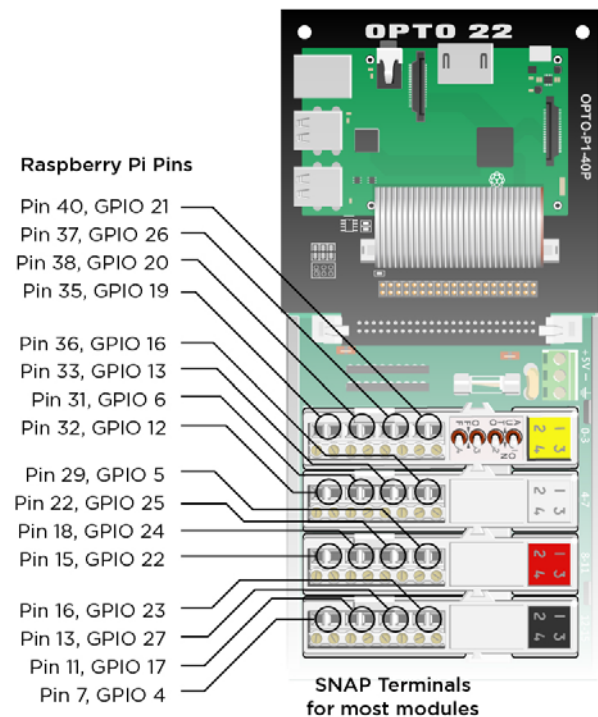

Read and Write with Pi

It's easy to read and write to Opto 22 I/O points using your favorite Pi-supported language like Python, Node-RED, Pi Terminal, Pi Filesystem GPIO, and many more.

Visit developer.opto22.com for code samples and tips for using your Pi to read and write to Opto 22 I/O modules.

NOTE: Opto 22 I/O modules use negative true logic; that is, a zero bit means On and a 1 bit means Off.

When reading and writing to I/O points, remember that 0 is On and 1 is Off.

Digital I/O Carrier Board for Raspberry Pi

Mapping Overlay for Raspberry Pi

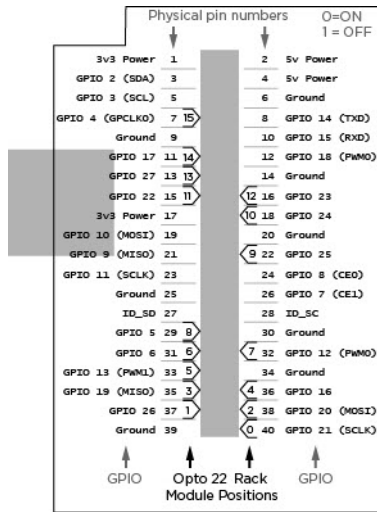

Place this overlay over your Pi's GPIO pins for a handy mapping reference. You can download the template from developer.opto22.com.

Dimensional Drawing

OPTO-P1-40P

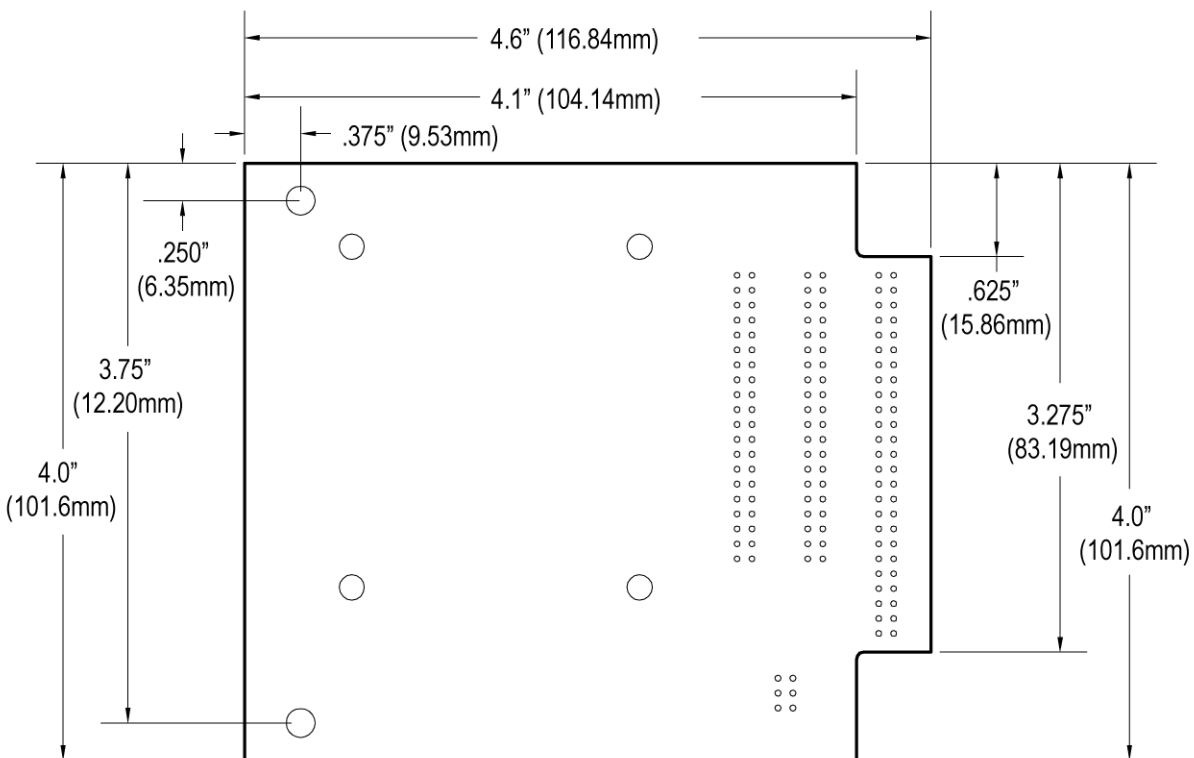

PRODUCTS

Opto 22 develops and manufactures reliable, easy-to-use, open standards-based hardware and software products used worldwide.

Industrial automation, process control, building automation, industrial refrigeration, remote monitoring, data acquisition, and Industrial Internet of Things (IIoT) applications all rely on Opto 22.



groov

Monitor and control your equipment from anywhere using your smartphone or tablet with groov. Build your own mobile app easily—just drag, drop, and tag. No programming or coding. Visit groov.com for more information and your free trial.

SNAP PAC System

Developer- and IIoT-ready, the SNAP PAC System connects physical assets to databases and applications using open standards. The SNAP PAC System consists of four integrated components:

- SNAP PAC controllers
- PAC Project™ Software Suite
- SNAP PAC brains
- SNAP I/O™

SNAP PAC Controllers

SNAP PAC programmable automation controllers handle a wide range of digital, analog, and serial functions for data collection, remote monitoring, process control, and discrete and hybrid manufacturing.

For IIoT applications and easier integration with company systems, standalone and rack-mounted SNAP PACs include a built-in HTTP/HTTPS server and **RESTful API** (application program interface). The REST API gives you secure, direct access to I/O and variable data using your choice of programming languages. No middleware, protocol converters, drivers, or gateways needed.

Based on open Ethernet and Internet Protocol (IP) standards, SNAP PACs make it easier to build or extend a system without the expense and limitations of proprietary networks and protocols.

PAC Project Software Suite

Opto 22's PAC Project Software Suite offers full-featured, cost-effective control programming, HMI (human machine interface), OPC server, and database connectivity software.

Control programming includes both easy-to-learn flowcharts and optional scripting. Commands are in plain English; variables and I/O point names are fully descriptive.

PAC Project Basic offers control and HMI tools and is free for download on our website, www.opto22.com. PAC Project Professional, available for separate purchase, adds one SoftPAC software-based controller, OptoOPCServer, OptoDataLink, options for controller redundancy or segmented networking, and support for legacy Opto 22 serial *mistic*™ I/O units.

SNAP PAC Brains

While SNAP PAC controllers provide central control and data distribution, SNAP PAC brains provide distributed intelligence for I/O processing and communications. Brains offer analog, digital, and serial functions, including thermocouple linearization, local PID loop control, watchdog, totalizing, and much more.

SNAP I/O

I/O provides the local connection to sensors and equipment. Opto 22 SNAP I/O offers 1 to 32 points of reliable I/O per module. Analog, digital, and serial modules are mixed on one mounting rack and controlled by a SNAP PAC brain or rack-mounted PAC.

QUALITY

Founded in 1974, Opto 22 has established a worldwide reputation for high-quality products. All are made in the U.S.A. at our manufacturing facility in Temecula, California.

Because we test each product twice before it leaves our factory, rather than only testing a sample of each batch, we can guarantee most solid-state relays and optically isolated I/O modules for life.



FREE PRODUCT SUPPORT

Opto 22's California-based Product Support Group offers free, comprehensive technical support for Opto 22 products from engineers with decades of training and experience. Support is available in English and Spanish by phone or email, Monday–Friday, 7 a.m. to 5 p.m. PST.

Support is always available on our website: how-to videos, user's guides, OptoKnowledgeBase, self-training guide, troubleshooting, and OptoForums. In addition, hands-on training is available for free at our Temecula, California headquarters, and you can [register online](#).

PURCHASING OPTO 22 PRODUCTS

Opto 22 products are sold directly and through a worldwide network of distributors, partners, and system integrators. For more information, contact Opto 22 headquarters at 800-321-6786 (toll-free in the U.S. and Canada) or 951-695-3000, or visit our website at www.opto22.com.