

SNAP D SERIES RACKS

(WITH AUXILIARY TERMINAL STRIP)

Features

- > Ideal for discrete control applications
- > Control directly or through an Opto 22 PC adapter card
- > Use panel or DIN-rail mounting
- > Modules snap into place

DESCRIPTION

Opto 22 SNAP "D Series" racks are designed for discrete control applications and can accommodate 4, 6, 8, or 12 SNAP 4-channel digital modules. These racks use an industry-standard 50-pin header connector, which allows them to be used in a variety of applications.

The logic side of the I/O circuitry can be controlled directly or by using an Opto 22 PCIe-AC5 (PCI Express bus), PCI-AC5 (PCI bus) or G4AC5 or AC5 (ISA bus) PC adapter card.

In addition, the 4-module-position **SNAP-D4M** can be used with Opto 22's Classic brain boards. These boards use one of Opto 22's industry-standard protocols (*mistic*[®], *Optomux*[®], or *Pamux*[®]) to control the I/O and communicate either serially or in parallel

The MC and MC-P model racks provide an auxiliary screwtype terminal strip for additional wiring requirements. The MC racks use a fixed terminal strip while the MC-P uses removable connectors for easy maintenance (see enlarged view below).

Field devices are wired directly to the top-mounted removable connectors on the SNAP I/O[®] modules. The module and rack design allows modules to simply "snap" on and off the mounting rack.

SNAP racks use a retention rail locking system that holds modules securely to the rack. Normally, a hold-down screw is not required. However, for applications that require additional mounting security, SNAP racks have provisions for two 4-40 by 1/2-inch standard machine screws to hold each module in position.

All SNAP racks offer panel mounting and the option of DIN-rail mounting. SNAP racks use a single 5 VDC power source.

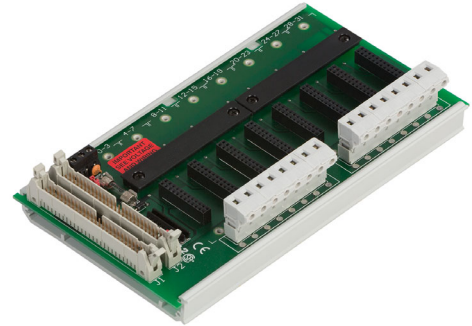

SNAP-D8MC Rack

Part Numbers

Part	Description
SNAP-D4MC	SNAP I/O mounting rack: Digital 4-module rack with header connector. Common terminal block
SNAP-D4MC-P [Obsolete]	[Obsolete] SNAP I/O mounting rack: Digital 4-module rack with header connector. Common terminal block pluggable
SNAP-D6MC	SNAP I/O mounting rack: Digital 6-module rack with header connector. Common terminal block
SNAP-D6MC-P [Obsolete]	[Obsolete] SNAP I/O mounting rack: Digital 6-module rack with header connector. Common terminal block pluggable
SNAP-D8MC	SNAP I/O mounting rack: Digital 8-module rack with header connector. Common terminal block
SNAP-D8MC-P [Obsolete]	[Obsolete] SNAP I/O mounting rack: Digital 8-module rack with header connector. Common terminal block pluggable
SNAP-D12MC	SNAP I/O mounting rack: Digital 12-module rack with header connector. Common terminal block
SNAP-D12MC-P [Obsolete]	[Obsolete] SNAP I/O mounting rack: Digital 12-module rack with header connector. Common terminal block pluggable
SNAP-CDBBIN	Classic digital brain board DIN-rail adapter
SNAP-FUSE1A	SNAP 1-Amp fuse
SNAP-TEX-DRC-10	SNAP PAC rack DIN-rail adapter clip, 10-pack

SPECIFICATIONS: SNAP-D4MC/MC-P (4 MODULE POSITION)

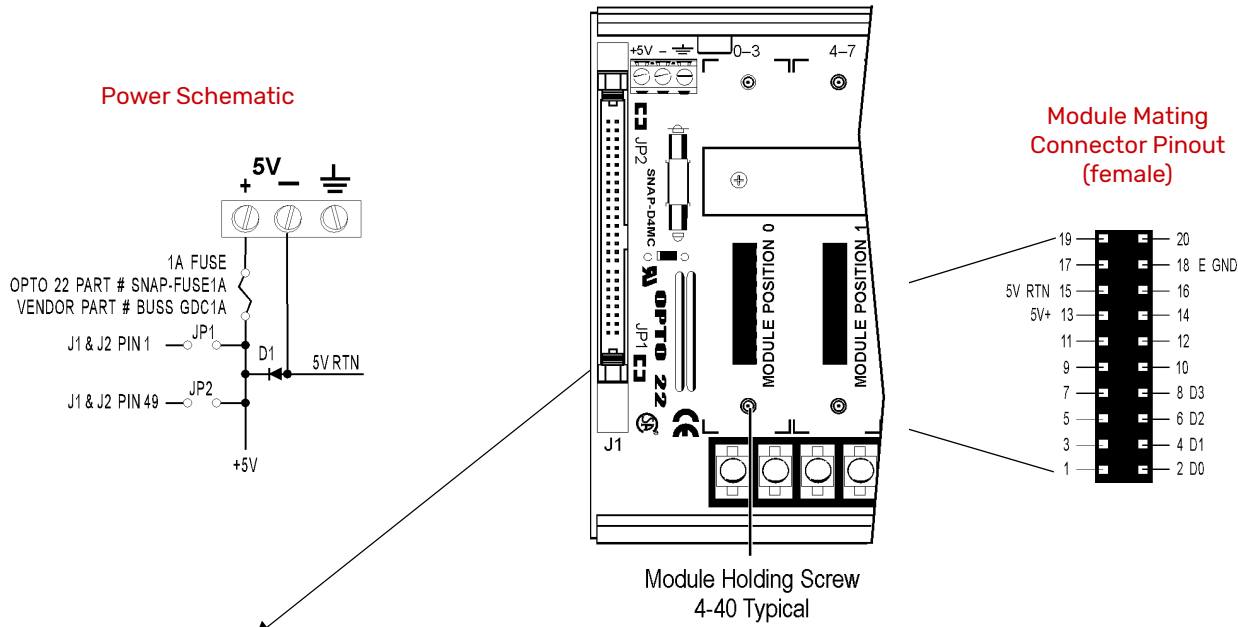

Control Connector (50-pin male)

Module Position	Channel Position	J1 Control Connector
0	0	47
	1	45
	2	43
	3	41
	4	39
1	5	37
	6	35
	7	33
	8	31
2	9	29
	10	27
	11	25
	12	23
3	13	21
	14	19
	15	17

Operating Requirements

Power Requirements	5 VDC \pm 0.1 VDC @ 200 mA max. (700 mA with brain board)
Operating Temperature Range	0° to 70°C
Relative Humidity	95%, non-condensing
Agency Approvals	UL, CE, RoHS, DFARS; UKCA

Notes:

- Even pins on control connectors are connected to 5V RTN.
- Pin 1 of control connector J1 is connected common to +5V through jumper JP1.
- Pin 49 of control connector J1 is connected common to +5V through jumper JP2.
- For operation of SNAP-D4MC/MC-P with Classic plug-in brain boards (B100, B1, and B5), install jumpers JP1 and JP2.
- For operation with PC adapter cards (i.e. G4AC5), remove jumpers JP1 and JP2.
- Odd numbered pins 3 through 15 of control connector are not used.

SPECIFICATIONS: SNAP-D6MC/MC-P (6 MODULE POSITION)

Power Schematic

1A FUSE
OPTO 22 PART # SNAP-FUSE1A
VENDOR PART # BUSS GDC1A

D1

5V RTN

+5V

Module Mating Connector Pinout (female)

19 20
17 18 E GND
15 16
5V+ 13 14
11 12
9 10
7 8 D3
5 6 D2
3 4 D1
1 2 D0

Connection Diagram for 12-position terminal strip

For detailed information on terminal strip, see pages 9-10.

Module Position	Channel Position	Control Connector
0	0	47
	1	45
	2	43
	3	41
	4	39
1	5	37
	6	35
	7	33
	8	31
2	9	29
	10	27
	11	25
	12	23
3	13	21
	14	19
	15	17
	16	15
4	17	13
	18	11
	19	9
	20	7
5	21	5
	22	3
	23	1

Operating Requirements

Power Requirements	5 VDC ± 0.1 VDC @ 300 mA max.
Operating Temperature Range	0° to 70°C
Relative Humidity	95%, non-condensing
Agency Approvals	UL, CE, RoHS, DFARS; UKCA

Notes:

- Even pins on control connectors are connected to 5V RTN.
- SNAP-D6MC/MC-P is designed to interface with PC adapter cards (i.e. AC5 or G4AC5). It will not work with brain boards because there is no power to the control connector.
- Pin 49 - "no" connection.

SPECIFICATIONS: SNAP-D8MC/MC-P (8 MODULE POSITION)

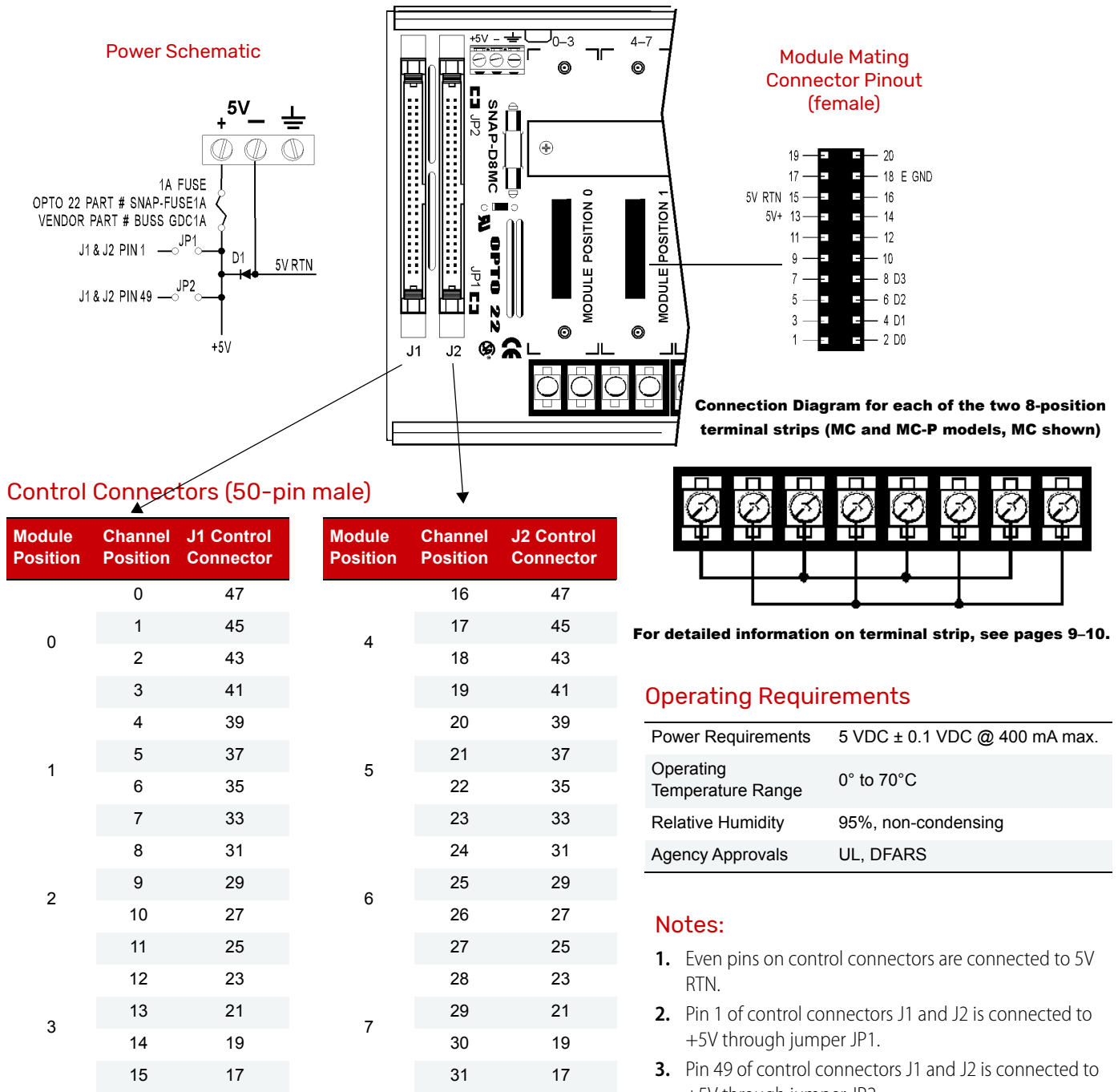

For detailed information on terminal strip, see pages 9-10.

Operating Requirements

Power Requirements	5 VDC ± 0.1 VDC @ 400 mA max.
Operating Temperature Range	0° to 70°C
Relative Humidity	95%, non-condensing
Agency Approvals	UL, DFARS

Notes:

- Even pins on control connectors are connected to 5V RTN.
- Pin 1 of control connectors J1 and J2 is connected to +5V through jumper JP1.
- Pin 49 of control connectors J1 and J2 is connected to +5V through jumper JP2.
- For operation with PC adapter cards (i.e. AC5 or G4AC5), remove jumpers JP1 and JP2.
- Odd numbered pins 3 through 15 of control connectors are not used.

SPECIFICATIONS: SNAP-D12MC/MC-P (12 MODULE POSITION)

Power Schematic

1A FUSE
OPTO 22 PART # SNAP-FUSE1A
VENDOR PART # BUSS GDC1A

D1

5V RTN

+5V

SNAP-D12MC

OPTO 22

MODULE POSITION 0

MODULE POSITION 1

J1

J2

Module Mating Connector Pinout (female)

19	20
17	18 E GND
15	16
13	14
11	12
9	10
7	8 D3
5	6 D2
3	4 D1
1	2 D0

5V RTN

5V+

Control Connectors (50-pin male)

Module Position	Channel Position	J1 Control Connector
0	0	47
	1	45
	2	43
	3	41
	4	39
1	5	37
	6	35
	7	33
	8	31
	9	29
2	10	27
	11	25
	12	23
	13	21
	14	19
3	15	17
	16	15
	17	13
	18	11
	19	9
4	20	7
	21	5
	22	3
	23	1
	5	0
1		45
2		43
3		41
4		39
6	5	37
	6	35
	7	33
	8	31
	9	29
7	10	27
	11	25
	12	23
	13	21
	14	19
8	15	17
	16	15
	17	13
	18	11
	19	9
9	20	7
	21	5
	22	3
	23	1
	10	0
1		45
2		43
3		41
4		39
11	5	37
	6	35
	7	33
	8	31
	9	29
12	10	27
	11	25
	12	23
	13	21
	14	19
13	15	17
	16	15
	17	13
	18	11
	19	9
14	20	7
	21	5
	22	3
	23	1

Connection Diagram for each of the two 8-position terminal strips (MC and MC-P models, MC shown)

For detailed information on terminal strip, see pages 9-10.

Operating Requirements

Power Requirements	5 VDC ± 0.1 VDC @ 1200mA max.
Operating Temperature Range	0° to 70°C
Relative Humidity	95%, non-condensing
Agency Approvals	UL, CE, RoHS, DFARS; UKCA

Notes

- Even pins on control connectors are connected to 5V RTN.
- SNAP-12MC/MC-P is designed to interface with PC adapter cards (i.e. AC5 or G4AC5). It will not work with brain boards because there is no power to the control connector.

DIMENSIONAL DRAWING

Front View (when Mounted)—All Models

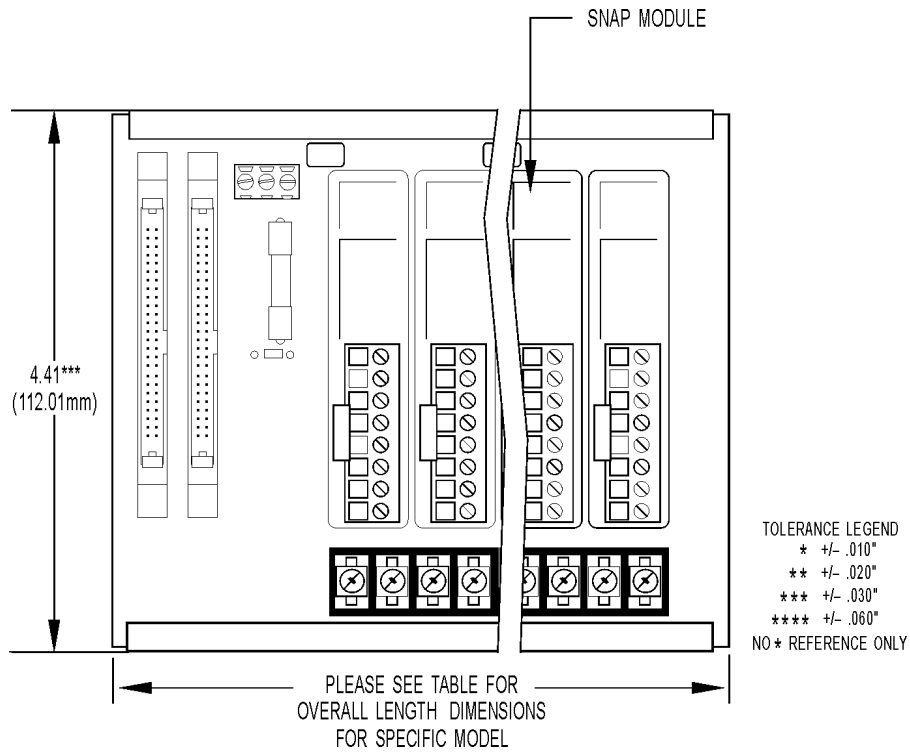

Overall Length Dimension (All Models)

Part Numbers	Description	Length (inches)	Length (mm)
SNAP-D4M	4-module rack	4.19	106.43
SNAP-D6M	6-module rack	5.74	145.8
SNAP-D8M	8-module rack	7.74	196.6
SNAP-D12M	12-module rack	10.74	272.8

DIMENSIONAL DRAWING

Right Side View (with DIN-Rail Option)—All Models

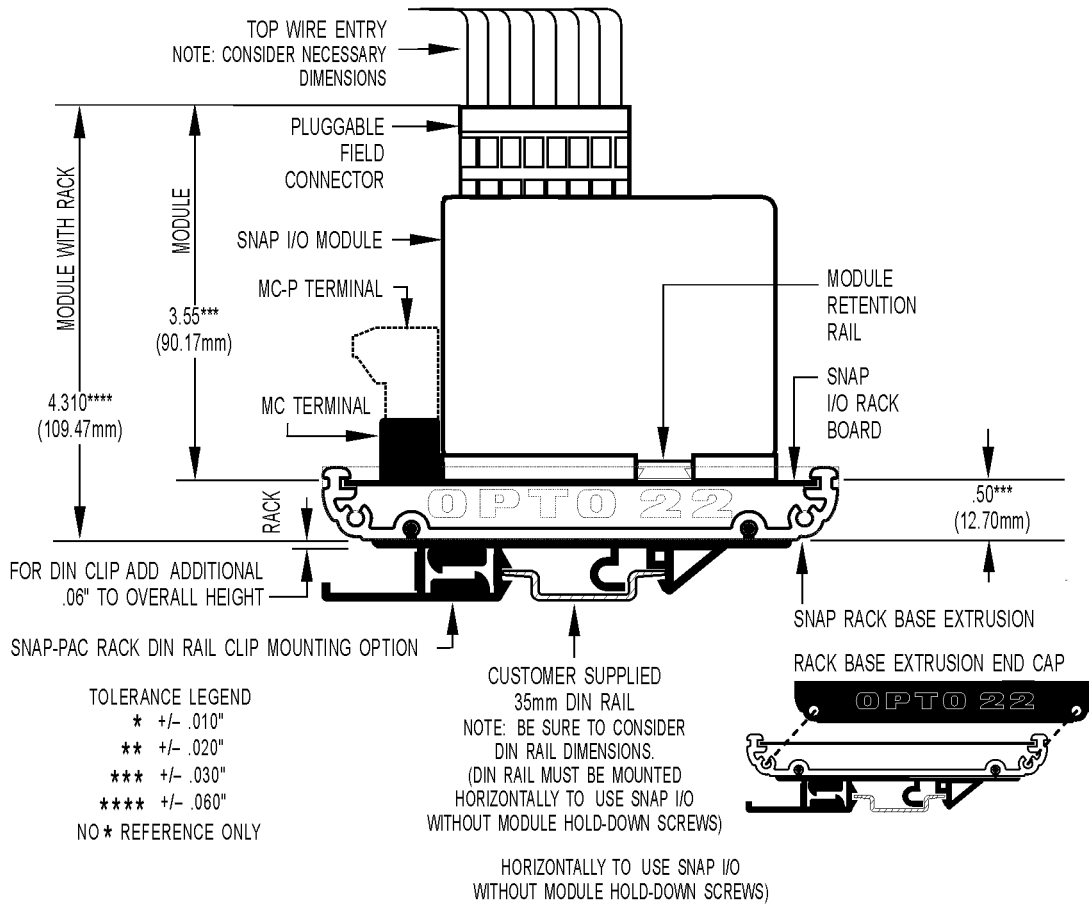

DIMENSIONAL DRAWING

Typical Plain View of SNAP Mounting Extrusion—All Models

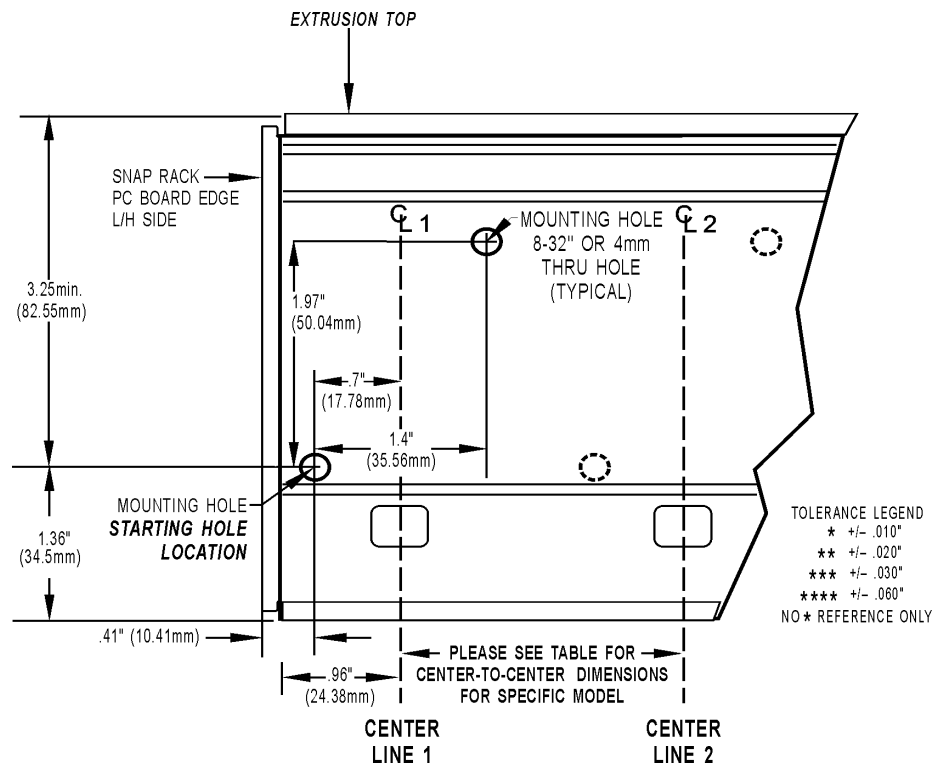

General Mounting Instructions

If not using module hold-down screws, the SNAP rack assembly should be mounted horizontally, as shown in diagram.

Preferred Method: Template (product on site)

1. Use SNAP rack mounting extrusion as template.
2. Be sure to use drawing to determine required product and option clearances.

Alternate Method: Prefabrication of Panels (no product on site)

1. Mounting holes are in sets of two located on lower left and upper right, with respect to a centerline (CL).
2. Using the drawing, determine CL1 mounting hole positions. (CL1 is located on the left side of all SNAP rack mounting extrusions.)
3. Use the center-to-center length specification table to determine offset between centerlines and number of centerline positions for each model.
4. Repeat process for each centerline position.
5. Dimensions shown in drawing apply to all models.

Center-to-Center Length (All Models)

Part Numbers	Description	Center-to-Center Length	# of Center Positions
SNAP-D4MC	4-module rack with extra terminal block for field wiring	1.98	2
SNAP-D4MC-P [Obsolete]	[Obsolete] 4-module rack with extra terminal block for field wiring, pluggable	1.98	2
SNAP-D6MC	6-module rack with extra terminal block for field wiring	3.53	2
SNAP-D6MC-P [Obsolete]	[Obsolete] 6-module rack with extra terminal block for field wiring, pluggable	3.53	2
SNAP-D8MC	8-module rack with extra terminal block for field wiring	5.53	2
SNAP-D8MC-P [Obsolete]	[Obsolete] 8-module rack with extra terminal block for field wiring, pluggable	5.53	2
SNAP-D12MC	12-module rack with extra terminal block for field wiring	4.26	3
SNAP-D12MC-P [Obsolete]	[Obsolete] 12-module rack with extra terminal block for field wiring, pluggable	4.26	3

SCHEMATICS: TERMINAL STRIP USAGE - DIGITAL

Typical Digital Input Using Terminal Strip

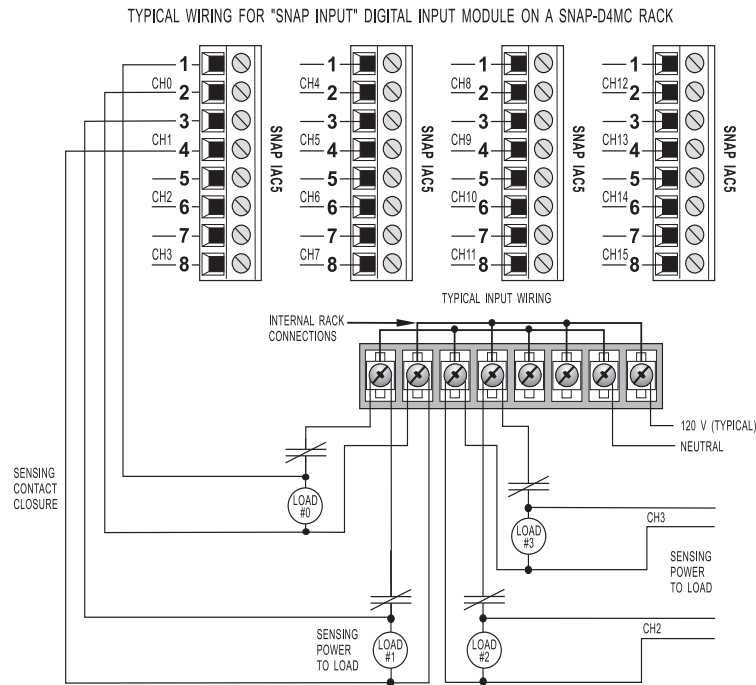

Typical Digital AC Output Using Terminal Strip

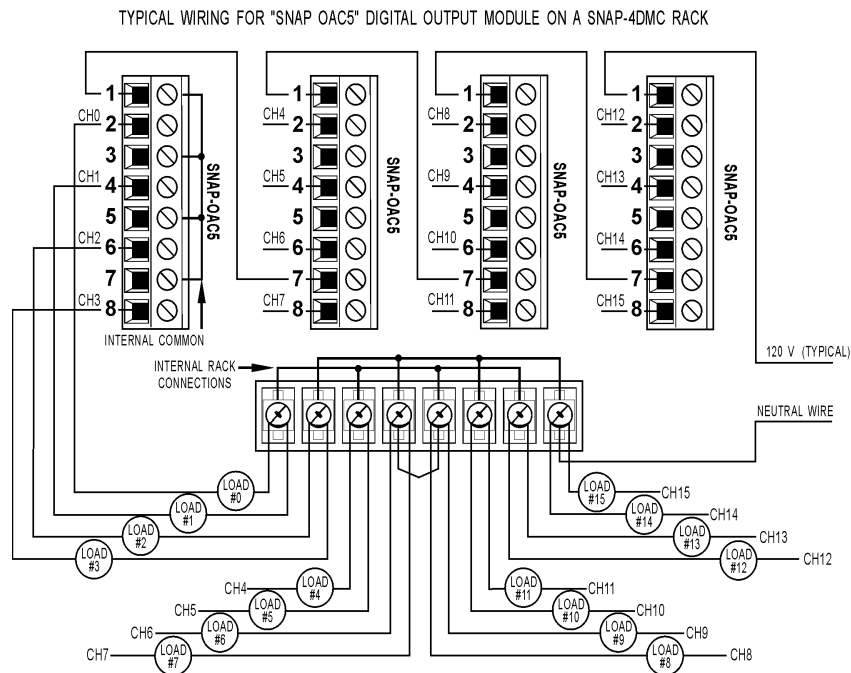

SCHEMATICS: TERMINAL STRIP USAGE - DIGITAL

Typical Digital DC Output (Sourcing) Using Terminal Strip

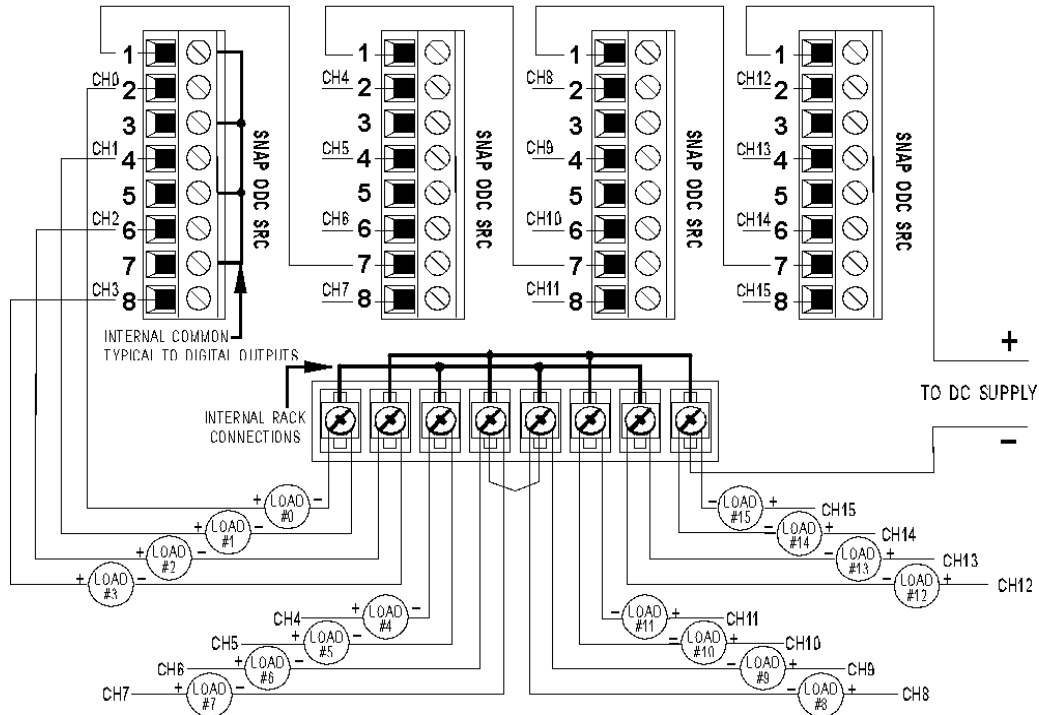

Typical Digital DC Output (Sinking) Using Terminal Strip

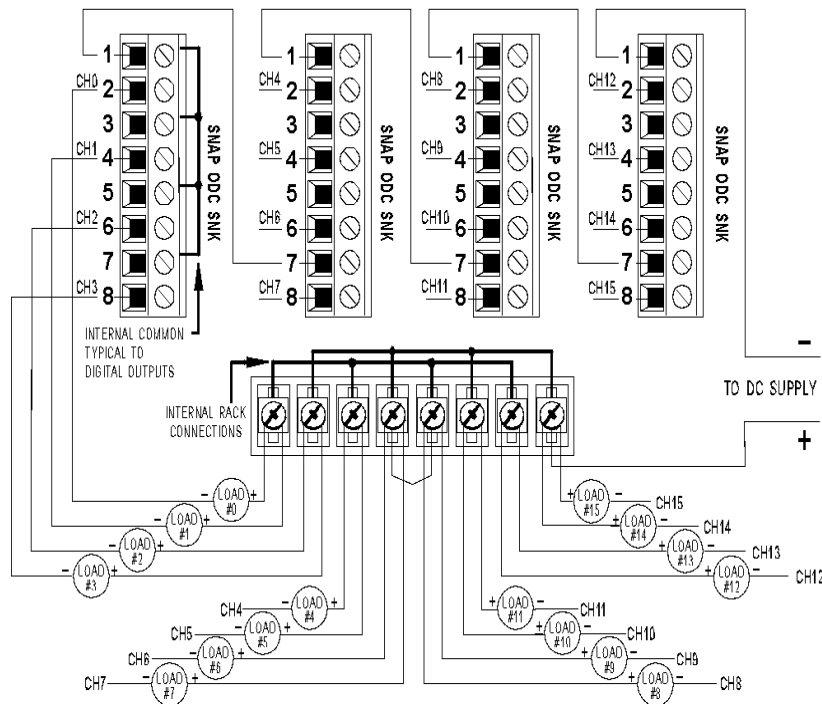

PRODUCTS

Opto 22 develops and manufactures reliable, easy-to-use, open standards-based hardware and software products. Industrial automation, process control, remote monitoring, data acquisition, and industrial internet of things (IIoT) applications worldwide all rely on Opto 22.

groov RIO®

groov RIO edge I/O offers a single, compact, PoE-powered industrial package with web-based configuration and IIoT software built in, support for multiple OT and IT protocols, and security features like a device firewall, data encryption, and user account control.

Standing alone, groov RIO connects to sensors, equipment, and legacy systems, collecting and securely publishing data from field to cloud. Choose a universal I/O model with thousands of possible field I/O configurations, with or without Ignition from Inductive Automation®, or a RIO EMU energy monitoring unit that reports 64 energy data values from 3-phase loads up to 600 VAC, Delta or Wye.

You can even write an IEC 61131-3 compliant control program to run on groov RIO, using CODESYS. You can also use groov RIO with a Modbus/TCP master or as remote I/O for a groov EPIC system.

groov EPIC® System

Opto 22's groov Edge Programmable Industrial Controller (EPIC) system gives you industrially hardened control with a flexible Linux®-based processor with gateway functions, guaranteed-for-life I/O, and software for your automation and IIoT applications.

groov EPIC Processor

The heart of the system is the groov EPIC processor. It handles a wide range of digital, analog, and serial functions for data collection, remote monitoring, process control, and discrete and hybrid manufacturing.

In addition, the EPIC provides secure data communications among physical assets, control systems, software applications, and online services, both on premises and in the cloud. No industrial PC needed.

Configuring and troubleshooting I/O and networking is easier with the EPIC's integrated high-resolution color touchscreen. Authorized users can manage the system locally on the touchscreen, on a monitor connected via the HDMI or USB ports, or on a PC or mobile device with a web browser.

groov EPIC I/O

groov I/O connects locally to sensors and equipment. Modules have a spring-clamp terminal strip, integrated wireway, swing-away cover, and LEDs indicating module health and discrete channel status. groov I/O is hot swappable, UL Hazardous Locations approved, and ATEX compliant.

groov EPIC Software

The groov EPIC processor comes ready to run the software you need:

- Programming: Choose flowchart-based PAC Control, CODESYS Development System for IEC61131-3 compliant programs, or secure shell access (SSH) to the Linux OS for custom applications
- Node-RED for creating simple IIoT logic flows from pre-built nodes
- Efficient MQTT data communications with string or Sparkplug data formats
- Multiple OPC UA server options
- HMI: groov View to build your own HMI viewable on touchscreen, PCs, and mobile devices; PAC Display for a

Windows HMI; Node-RED dashboard UI

- Ignition or Ignition Edge® from Inductive Automation (requires license purchase) with OPC-UA drivers to Allen-Bradley®, Siemens®, and other control systems, and MQTT communications

Older products

From solid state relays, to world-famous G4 and SNAP I/O, to SNAP PAC controllers, older Opto 22 products are still supported and working hard at thousands of installations worldwide. You can count on us for the reliability and service you expect, now and in the future.

QUALITY

Founded in 1974, Opto 22 has established a worldwide reputation for high-quality products. All are made in the U.S.A. at our manufacturing facility in Temecula, California.

Because we test each product twice before it leaves our factory rather than testing a sample of each batch, we can afford to guarantee most solid-state relays and optically isolated I/O modules for life.

FREE PRODUCT SUPPORT

Opto 22's California-based Product Support Group offers free technical support for Opto 22 products from engineers with decades of training and experience. Support is available in English and Spanish by phone or email, Monday–Friday, 7 a.m. to 5 p.m. PST.

Support is always available on our website, including [free online training](#) at OptoU, how-to [videos](#), [user's guides](#), the Opto 22 KnowledgeBase, and [OptoForums](#).

PURCHASING OPTO 22 PRODUCTS

Opto 22 products are sold directly and through a worldwide network of distributors, partners, and system integrators. For more information, contact Opto 22 headquarters at **800-321-6786** (toll-free in the U.S. and Canada) or **+1-951-695-3000**, or visit our website at www.opto22.com.

