

SNAP I/O MODULE INTEGRATION GUIDE

Form 0876-100610—June 2010

OPTO 22

43044 Business Park Drive • Temecula • CA 92590-3614

Phone: 800-321-OPTO (6786) or 951-695-3000

Fax: 800-832-OPTO (6786) or 951-695-2712

www.opto22.com

Product Support Services

800-TEK-OPTO (835-6786) or 951-695-3080

Fax: 951-695-3017

Email: support@opto22.com

Web: support.opto22.com

SNAP I/O Module Integration Guide
Form 0876-100610—June 2010

Copyright © 1997–2010 Opto 22.
All rights reserved.
Printed in the United States of America.

The information in this manual has been checked carefully and is believed to be accurate; however, Opto 22 assumes no responsibility for possible inaccuracies or omissions. Specifications are subject to change without notice.

Opto 22 warrants all of its products to be free from defects in material or workmanship for 30 months from the manufacturing date code. This warranty is limited to the original cost of the unit only and does not cover installation, labor, or any other contingent costs. Opto 22 I/O modules and solid-state relays with date codes of 1/96 or later are guaranteed for life. This lifetime warranty excludes reed relay, SNAP serial communication modules, SNAP PID modules, and modules that contain mechanical contacts or switches. Opto 22 does not warrant any product, components, or parts not manufactured by Opto 22; for these items, the warranty from the original manufacturer applies. These products include, but are not limited to, OptoTerminal-G70, OptoTerminal-G75, and Sony Ericsson GT-48; see the product data sheet for specific warranty information. Refer to Opto 22 form number 1042 for complete warranty information.

Wired+Wireless controllers and brains and N-TRON wireless access points are licensed under one or more of the following patents: U.S. Patent No(s). 5282222, RE37802, 6963617; Canadian Patent No. 2064975; European Patent No. 1142245; French Patent No. 1142245; British Patent No. 1142245; Japanese Patent No. 2002535925A; German Patent No. 60011224.

Opto 22 FactoryFloor, Optomux, and Pamux are registered trademarks of Opto 22. Generation 4, ioControl, ioDisplay, ioManager, ioProject, ioUtilities, *mistic*, Nvio, Nvio.net Web Portal, OptoConnect, OptoControl, OptoDataLink, OptoDisplay, OptoOPCServer, OptoScript, OptoServer, OptoTerminal, OptoUtilities, PAC Control, PAC Display, PAC Manager, PAC Project, SNAP Ethernet I/O, SNAP I/O, SNAP OEM I/O, SNAP PAC System, SNAP Simple I/O, SNAP Ultimate I/O, and Wired+Wireless are trademarks of Opto 22.

ActiveX, JScript, Microsoft, MS-DOS, VBScript, Visual Basic, Visual C++, Windows, and Windows Vista are either registered trademarks or trademarks of Microsoft Corporation in the United States and other countries. Linux is a registered trademark of Linus Torvalds. Unicenter is a registered trademark of Computer Associates International, Inc. ARCNET is a registered trademark of Datapoint Corporation. Modbus is a registered trademark of Schneider Electric. Wiegand is a registered trademark of Sensor Engineering Corporation. Nokia, Nokia M2M Platform, Nokia M2M Gateway Software, and Nokia 31 GSM Connectivity Terminal are trademarks or registered trademarks of Nokia Corporation. Sony is a trademark of Sony Corporation. Ericsson is a trademark of Telefonaktiebolaget LM Ericsson. CompactLogix and RSLogix are trademarks of Rockwell Automation. Allen-Bradley and ControlLogix are registered trademarks of Rockwell Automation. CIP and EtherNet/IP are trademarks of ODVA.

All other brand or product names are trademarks or registered trademarks of their respective companies or organizations.

Table of Contents

OPTO 22

Chapter 1: Introduction	1
SNAP I/O Modules	1
Choosing SNAP I/O Modules	1
Communicating with SNAP I/O Modules	2
About this Guide	2
For Help	3
Chapter 2: Interfaces	5
Mechanical Interface	5
All Modules	5
Using Modules with an Opto 22 Mounting Rack	5
Using Modules without an Opto 22 Mounting Rack	6
Electrical Interface	7
4-Channel Digital Input/Output Modules	7
Analog Modules	8
Resolution and Range	9
Analog Module Power Requirements	9
Other Modules	9
Serial Communication Modules	9
SNAP Module Power Requirements	10
Chapter 3: Communication Protocols	11
Introduction	11
Serial Protocol (Binary or ASCII)	11
Addressing	11
Module Addresses	12
Point Numbers	12

Serial Communication	13
Serial Protocol Details	13
Message Field Definitions—Serial Protocol Packet	14
About Data Verification	14
Calculating a Checksum	14
Calculating a CRC16	15
Serial Message Examples	15
Command Message Format	15
Response Message Format	16
ARCNET Protocol	17
Addressing	17
Point Numbers	17
Communication	17
ARCNET Protocol Details	18
Message Field Definitions—ARCNET Protocol Packet	18
ARCNET Message Examples	18
Command Message Format	18
Response Message Format	19
Global Protocol Definitions	20
Product Categories	20
Message Types	20
Error Responses	20
Module Types, Channel Modes, and Point Types	21
Analog Input Modules with Four Points or Less	21
Analog Input Modules with More than Four Points	23
Analog Output, Serial, and High-Density Digital Modules	24

Chapter 4: Commands 25

Introduction	25
Command List	26
Command Details	28
Read Number of Received Data Bytes Waiting ... Command 23	28
Command Data Required	28
Response Data Received	28
Read Channel Mode	28
Command Data Required	28
Response Data Received	28

Set Channel Mode	Command 3A	29
Command Data Required		29
Response Data Received		29
Set Point Configuration	Command 3C	29
Command Data Required		29
Response Data Received		29
Powerup Clear—Current Modules	Command 40	30
Command Data Required		30
Response Data Received		30
Powerup Clear—Legacy Modules	Command 41	31
Command Data Required		31
Response Data Received		31
Reset	Command 42	31
Command Data Required		31
Response Data Received		31
Read Amount of Unused Space in Transmit Buffer	Command 42	32
Command Data Required		32
Response Data Received		32
Save Current Module Configuration in EEPROM	Command 45	32
Command Data Required		32
Response Data Received		32
Identify Module Type	Command 46	33
Command Data Required		33
Response Data Received		33
Set Serial Port Configuration	Command 47	33
Command Data Required		33
Response Data Received		33
Set Serial Port Response Delay	Command 48	34
Command Data Required		34
Response Data Received		34
Read Module Firmware Version	Command 49	34
Command Data Required		34
Response Data Received		34
Group Read	Command 52	35
Command Data Required		35
Response Data Received		35
Group Read	Command 52	35
Command Data Required		35
Response Data Received		35

Read Status—Latches Not Cleared	Command 52	36
Command Data Required		36
Response Data Received		36
Receive Serial Data	Command 52	36
Command Data Required		36
Response Data Received		36
Group Write	Command 53	37
Command Data Required		37
Response Data Received		37
Read Status—Latches Cleared	Command 53	37
Command Data Required		37
Response Data Received		37
Read HDD Counters—Counters Not Cleared	Command 54	38
Command Data Required		38
Response Data Received		38
Read HDD Counters—Counters Cleared	Command 55	38
Command Data Required		38
Response Data Received		38
Channel Read	Command 55	39
Command Data Required		39
Response Data Received		39
Channel Write	Command 56	39
Command Data Required		39
Response Data Received		39
Set TPO Period	Command 57	40
Command Data Required		40
Response Data Received		40
Write Outputs	Command 58	40
Command Data Required		40
Response Data Received		40
Read Status (TPO, Inhibit On/off)	Command 58	41
Command Data Required		41
Response Data Received		41
Clear Serial Port Receive Buffer	Command 63	41
Command Data Required		41
Response Data Received		41
Read Serial Port CTS	Command 66	42
Command Data Required		42
Response Data Received		42

Set Serial Port RTS	Command 66	42
Command Data Required		42
Response Data Received		42
Clear Serial Port RTS	Command 66	43
Command Data Required		43
Response Data Received		43
Read Serial Module Info	Command 69	43
Command Data Required		43
Response Data Received		43
Read Serial Port Configuration	Command 71	44
Command Data Required		44
Response Data Received		44
Write Serial Port Configuration	Command 71	45
Command Data Required		45
Response Data Received		45
Write Serial Port Configuration and Store to Flash	Command 71	46
Command Data Required		46
Response Data Received		46
Receive Line of Serial Data	Command 72	46
Command Data Required		46
Response Data Received		46
Send & Receive Serial Data	Command 73	47
Command Data Required		47
Response Data Received		47
Send Serial Data	Command 74	47
Command Data Required		47
Response Data Received		47

Index	49
--------------------	-----------



1: Introduction

This guide provides information needed by original equipment manufacturers (OEMs) and others who use SNAP input/output (I/O) modules without a SNAP serial or Ethernet-based brain.

This guide also applies to OEMs using SNAP I/O modules with an Opto 22 OEM brain such as the SNAP-ARL-ASDS. I/O module physical and electrical interfaces and specifications are included, as well as details of the protocols necessary for communication.

SNAP I/O Modules

SNAP I/O modules were designed as OEM products and also as components of Opto 22 SNAP I/O systems. SNAP module types include:

- Four-channel SNAP **digital modules**—Each module provides four input or four output points. AC and DC models are available with a wide variety of voltages; dry contact models are also available.
- SNAP **high-density digital** modules, each providing more than four input or output points.
- SNAP **analog modules**—Analog modules provide one to 32 input or output points, depending on the model. Inputs include voltage, current, thermocouple, RTD, and others. Outputs are current, voltage, or time-proportional output.
- SNAP **serial communication** modules, each with two channels for RS-232 or RS-485/422 communication, depending on the model. (Other SNAP serial modules are not documented in this guide.)



Choosing SNAP I/O Modules

To choose modules for your application, see our website, www.opto22.com, or refer to the following data sheets,

which are available on our website. The easiest way to locate a data sheet is to search on its form number.

Data sheet	Form #
SNAP Digital Input Modules Data Sheet	773
SNAP Digital Output Modules Data Sheet	1144
SNAP Analog Input Modules Data Sheet	1065
SNAP Analog Output Modules Data Sheet	1066
SNAP Isolated Analog Input Modules Data Sheet	1182
SNAP Serial Communication Modules Data Sheet	1184
SNAP High-Density Digital Module Data Sheet	1556

Communicating with SNAP I/O Modules

Many SNAP I/O modules can be used either with or without an Opto 22 mounting rack and with or without an Opto 22 brain.

If you are using a Linux-based OEM brain, you must use an Opto 22 rack, because the brain's only method of communicating with analog and special-purpose modules is via the ARCNET communication built into the rack.

The following table shows the methods of communication available for each type of module.

Module type	Interface or protocol
4-Channel Digital	5 VDC logic (No protocol needed)
Analog	ARCNET* Serial binary or serial ASCII
High-density digital	ARCNET*
Serial	ARCNET*

*When used with a Linux-based OEM brain, communication with analog, high-density digital, serial, and special-purpose modules is via ARCNET on an Opto 22 mounting rack. A driver is available for this brain; see the readme file included with the driver for details.

About this Guide

This guide covers hardware, electrical, and protocol interfaces to SNAP digital, analog, and special-purpose modules. This guide assumes that you are already familiar with the communication protocols you will use.

The following sections are included in this guide:

Chapter 1: Introduction—Information about the guide and how to reach Product Support

Chapter 2: Interfaces—Mechanical interface, including board layout and module mounting; and electrical interface, including signal, power, ground, and data connections

Chapter 3: Communication Protocols—Details of the serial (binary or ASCII) and ARCNET protocols used to communicate with SNAP I/O modules, including addressing, communication details, and packet information

Chapter 4: Commands—Complete list of commands and the protocols they are used with, plus details of the data required for each command.

For Help

If you have problems using SNAP I/O modules and cannot find the help you need in this guide or on our Web site, contact Opto 22 Product Support.

Phone: 800-TEK-OPTO (835-6786)
951-695-3080
(Hours are Monday through Friday,
7 a.m. to 5 p.m. Pacific Time)

Fax: 951-695-3017

Email: support@opto22.com

Opto 22 website: www.opto22.com

NOTE: Email messages and phone calls to Opto 22 Product Support are grouped together and answered in the order received.

2: Interfaces

Mechanical Interface

All Modules

The following figure shows the mechanical interface for all SNAP modules. All dimensions are with reference to pin 1 of the electrical connector.

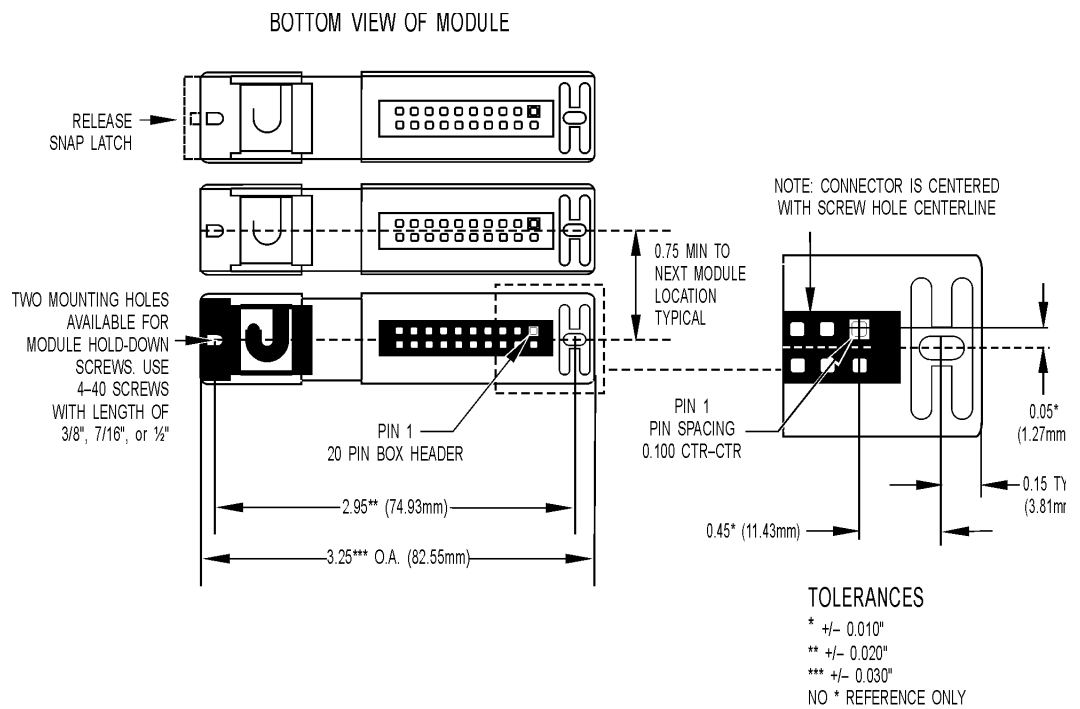

Using Modules with an Opto 22 Mounting Rack

If you are using an Opto 22 mounting rack, the retention rail is built into the rack. The following graphic shows a mounting rack with the retention rail.

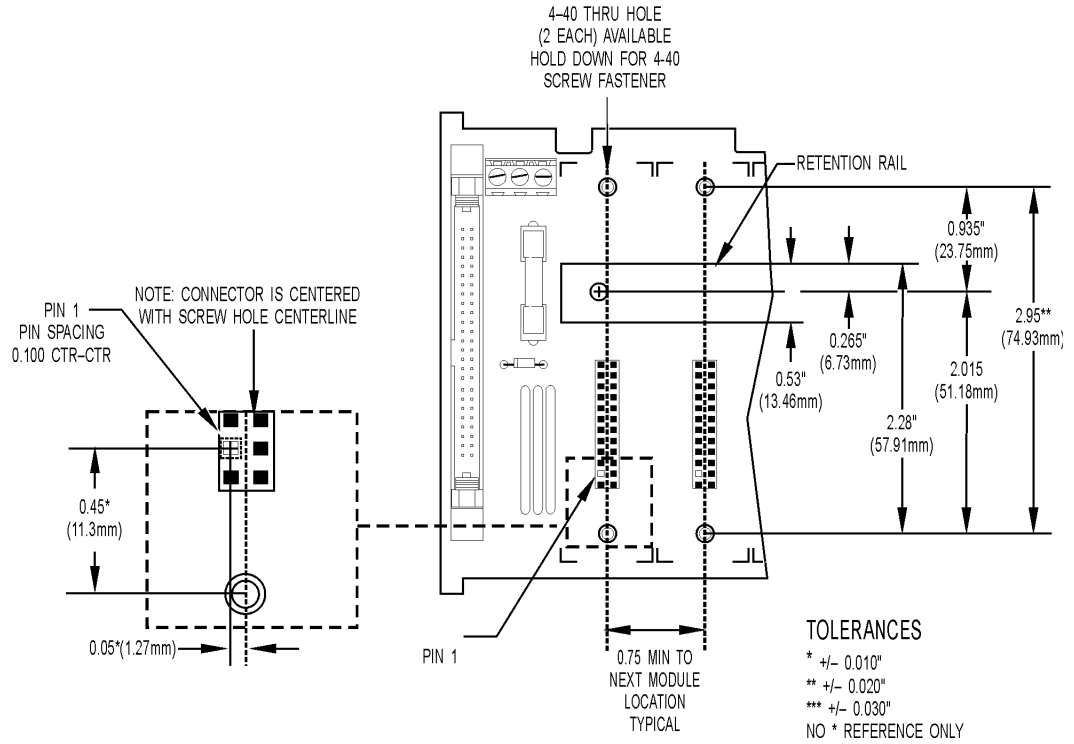

IMPORTANT: The mounting rack connector has 24 pins; the module connector has 20 pins. The extra pins on the mounting rack connector prevent misalignment of the module when installing.

Using Modules without an Opto 22 Mounting Rack

If you are not using an Opto 22 rack, lengths of retention rail suitable for mounting four modules or six modules are available from Opto 22 distributors. The rails come in packs of 25:

- SNAP-RETN4B (4-Module retention rail, 25 pack)
- SNAP-RETN6B (6-Module retention rail, 25 pack)

Connectors and PEM nuts can be ordered from the following sources:

RS2-24-GPC Board mount 24-pin connector

Adam Tech

909 Rahway Ave.

Union, New Jersey 07083

Phone: (908) 687-5000

Fax: (908) 687-5710

Email: info@adam-tech.com

PEM NUT 4-40PC Board mount PEM nut for 4-40 screws

Penn Engineering & Mfg

5190 Old Easton Rd.

Danboro, PA 18916

Phone: 800-342-5736

Fax: (215) 766-3633

Email: info@pennfast.com

Electrical Interface

4-Channel Digital Input/Output Modules

The bottom view of the module in the following diagram shows the electrical interface pin assignments for 4-channel digital modules. You read or write to each digital point using simple 5 VDC discrete signals.

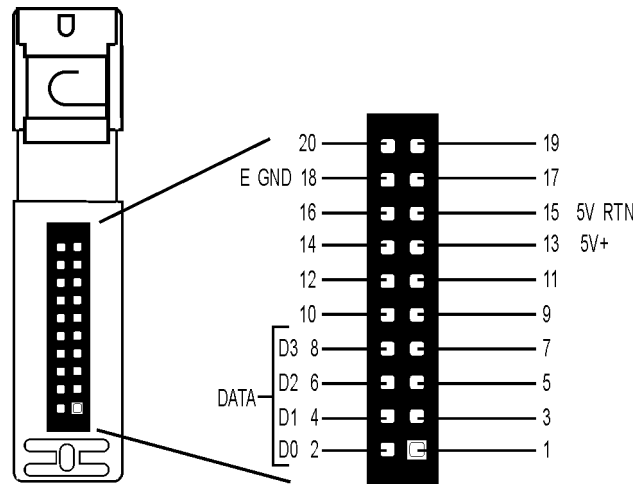

4-channel digital modules require only 5-volt power and TTL level data connections to signals D0 through D3 on pins 2, 4, 6, and 8. Like earlier Opto 22 digital modules, SNAP 4-channel digital modules use low-true logic (also called negative-true logic). A digital input point that is on returns a logic 0 signal. A logic 0 control signal turns on a digital output point.

Most 4-channel digital modules require approximately 50 mA for all four channels. SNAP-ICD5-SW and SNAP-IDC5SW-NC modules require 200 mA. [“SNAP Module Power Requirements” on page 10](#) lists requirements for all modules.

Analog Modules

The following figure shows the bottom view of the module with the electrical interface pin assignments for analog modules.

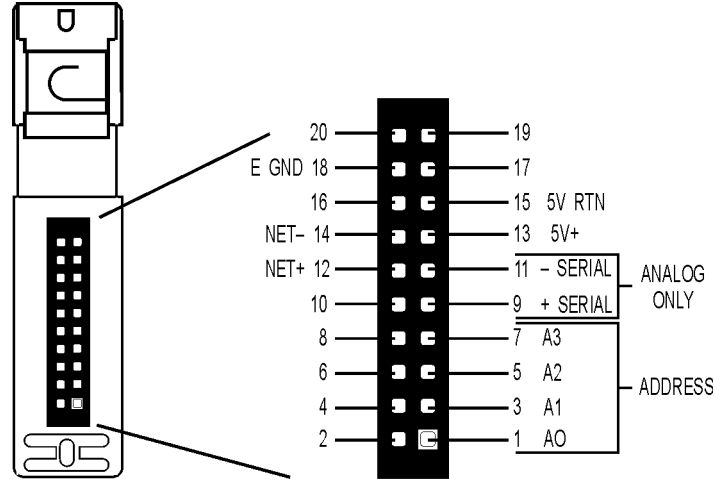

If you are using the serial protocol, the serial \pm connection is 2-wire RS-485. These data lines must be multidropped to corresponding connector pins for each analog module on the bus. Serial data lines must be terminated with a 220 Ohm resistor on the end of the communication network. The host end of the communication line must also be biased and terminated. Since the address range of the modules is 80 through 8F (hex), only 16 modules can be installed per data link.

If you are using ARCNET, NET+ and NET- are the ARCNET connections.

Other mandatory connections to the module are for +5 volt power, 5-volt return, Earth ground, and connections to pins 1, 3, 5, and 7, which set the module's address. For more information on addressing, see [page 11](#) for the serial protocol or [page 17](#) for the ARCNET protocol.

The diagram below shows a typical serial data link connection to an analog module.

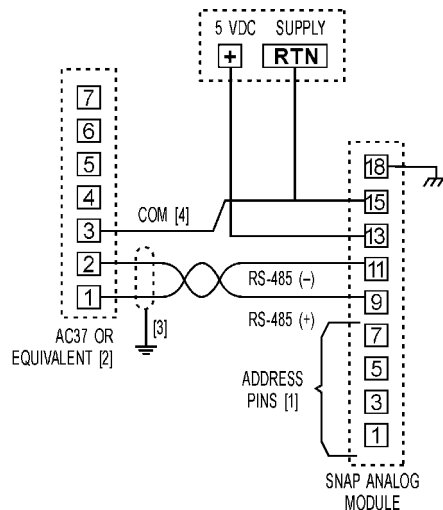

Notes:

1. Pins 1, 3, 5, and 7 set the module address. See "Module Addresses" on [page 12](#) for details.
2. An Opto 22 AC37 adapter card connection is shown as typical. Any RS-485 serial port may be used.
3. Optional shielding may be used to reduce noise on communications. Shields must not be grounded on both ends of the communication link, but should be grounded on one end only. Do NOT tie shield to signal common or 5 VDC return.
4. Optional COM (common) wire is recommended to reduce common-mode noise. Note that the COM connection is not connected to Earth ground.

Resolution and Range

SNAP analog input modules have approximately 15.5-bit resolution in the nominal range, supporting counts from -25,000 to +25,000. These modules support 10% over range and 10% under range. The following example illustrates resolution and range for a SNAP-AIV module:

Module	Channel mode	Nominal range	Under-range limit	Low scale	0%	High scale	Over-range limit
			-110%	-100%	100%	110%	
Counts							
			-27,500	-25,000	0	25,000	27,500
SNAP-AIV	0x22	-10 to +10 VDC	-11 VDC	-10 VDC	0 VDC	10 VDC	11 VDC
SNAP-AIV	0x32	-5 to +5 VDC	-5.5 VDC	-5 VDC	0 VDC	5 VDC	5.5 VDC

SNAP analog output modules have 12-bit resolution, supporting counts from 0 to 4095 for a total of 4096 counts. There are no under-range or over-range limits. Unipolar and bipolar modules both receive zero counts at low scale, as shown in the examples below:

Module	Nominal range	Low scale	High scale	
		0	2047	4095
SNAP-AOV-25	0 to +10 VDC	0 VDC	5 VDC	10 VDC
SNAP-AOV-27	-10 to +10 VDC	-10 VDC	0 VDC	10 VDC

Analog Module Power Requirements

See the table on [page 10](#).

Other Modules

Serial communication modules and high-density digital modules must be used with the ARCNET protocol. They cannot be used with the serial protocol.

See the table on [page 10](#) for power requirements.

Serial Communication Modules

IMPORTANT: Commands available for the ARCNET protocol apply only to the following serial communication modules:

- SNAP-SCM-232 Revision A modules (manufactured in June 2003 or after) with firmware R1.1e or higher. These modules support optional RTS/CTS flow control.
- SNAP-SCM-232 modules manufactured before June 2003 with firmware R1.1o. These modules do *not* support RTS/CTS flow control.
- SNAP-SCM-485-422 modules. (Modules manufactured before June 2003 with the part number SNAP-SCM-485 do not work with the commands in this guide.)

SNAP Module Power Requirements

Module	Requirements
SNAP-IDC5-SW	5 VDC @ 200 mA
SNAP-IDC5-SW-NC	5 VDC @ 200 mA
Other 4-ch. digital modules	5 VDC @ 50 mA
SNAP-IDC-16	5 VDC @ 150 mA
SNAP-IAC-16	5 VDC @ 150 mA
SNAP-IAC-A-16	5 VDC @ 150 mA
SNAP-IDC-32	5 VDC @ 150 mA
SNAP-ODC-32-SRC	5 VDC @ 150 mA
SNAP-ODC-32-SNK	5 VDC @ 150 mA
SNAP-AIARMS	5 VDC @ 170 mA
SNAP-AICTD	5 VDC @ 150 mA
SNAP-AICTD-4	5 VDC @ 150 mA
SNAP-AICTD-8	5 VDC @ 170 mA
SNAP-AILC	5 VDC @ 120 mA
SNAP-AILC-2	5 VDC @ 120 mA
SNAP-AIMA	5 VDC @ 170 mA
SNAP-AIMA-4	5 VDC @ 170 mA
SNAP-AIMA-8	5 VDC @ 170 mA
SNAP-AIMA-32	5 VDC @ 150 mA
SNAP-AIMA-i	5 VDC @ 200 mA
SNAP-AIMA-iSRC	5 VDC @ 200 mA
SNAP-AIMV-4	5 VDC @ 170 mA
SNAP-AIMV2-4	5 VDC @ 170 mA
SNAP-AIPM	5 VDC @ 100 mA
SNAP-AIPM-3	5 VDC @ 100 mA
SNAP-AIR40K-4	5 VDC @ 190 mA

Module	Requirements
SNAP-AIRATE	5 VDC @ 190 mA
SNAP-AIRTD	5 VDC @ 190 mA
SNAP-AIRTD-10	5 VDC @ 190 mA
SNAP-AITM	5 VDC @ 170 mA
SNAP-AITM-i	5 VDC @ 200 mA
SNAP-AITM-2	5 VDC @ 170 mA
SNAP-AITM2-i	5 VDC @ 200 mA
SNAP-AITM-8	5 VDC @ 200 mA
SNAP-AIV	5 VDC @ 170 mA
SNAP-AIV-i	5 VDC @ 200 mA
SNAP-AIV-4	5 VDC @ 170 mA
SNAP-AIV-8	5 VDC @ 170 mA
SNAP-AIV-32	5 VDC @ 150 mA
SNAP-AIV2-i	5 VDC @ 200 mA
SNAP-AIVRMS	5 VDC @ 170 mA
SNAP-AOA-3	5 VDC @ 140 mA
SNAP-AOV-5	5 VDC @ 150 mA
SNAP-AOA-23	5 VDC @ 150 mA
SNAP-AOV-25	5 VDC @ 150 mA
SNAP-AOV-27	5 VDC @ 150 mA
SNAP-AOA-28	5 VDC @ 150 mA
SNAP-AOD-29	5 VDC @ 150 mA
SNAP-SCM-232	5 VDC @ 250 mA
SNAP-SCM-485-422	5 VDC @ 250 mA
SNAP-SCM-PROFI	5 VDC @ 250 mA
SNAP-SCM-MCH16	5 VDC @ 250–1000 mA DC

3: Communication Protocols

Introduction

Opto 22 4-channel digital I/O modules require no protocol; they are simply read or written to using 5 VDC signals. Analog, high-density digital (HDD), and serial I/O modules, however, are “smart” modules. Each one includes a processor. As shown in the table on [page 2](#), the type of module determines the methods available to communicate with it.

This chapter includes detailed descriptions of the Serial (binary or ASCII) and ARCNET protocols.

Serial Protocol (Binary or ASCII)

Each analog (or HDD or serial) input or output module is actually an addressable analog processor that you can communicate with using either ASCII or binary serial modes. It is this on-module intelligence that makes these SNAP modules such a powerful OEM tool.

Addressing

Each I/O module has its own address. Sixteen modules can be addressed per communications link. Modules are addressed 80 through 8F hex.

Voltage to the module’s pins 1, 3, 5, and 7 determine the address, as shown in the table on the following page.

Module Addresses

Address (hex)	Pin 7	Pin 5	Pin 3	Pin 1
80	Ground	Ground	Ground	Ground
81	Ground	Ground	Ground	+5 Volts
82	Ground	Ground	+5 Volts	Ground
83	Ground	Ground	+5 Volts	+5 Volts
84	Ground	+5 Volts	Ground	Ground
85	Ground	+5 Volts	Ground	+5 Volts
86	Ground	+5 Volts	+5 Volts	Ground
87	Ground	+5 Volts	+5 Volts	+5 Volts
88	+5 Volts	Ground	Ground	Ground
89	+5 Volts	Ground	Ground	+5 Volts
8A	+5 Volts	Ground	+5 Volts	Ground
8B	+5 Volts	Ground	+5 Volts	+5 Volts
8C	+5 Volts	+5 Volts	Ground	Ground
8D	+5 Volts	+5 Volts	Ground	+5 Volts
8E	+5 Volts	+5 Volts	+5 Volts	Ground
8F	+5 Volts	+5 Volts	+5 Volts	+5 Volt

Point Numbers

Opto 22 point numbers on each module start with zero. The points on a four-channel analog input module, for example, are referred to as point 0, point 1, point 2, and point 3.

Serial Communication

Default settings for the serial communication baud rate and protocol are shown in the following table. To change serial port communication settings, use the bits shown in this table in the Data byte of command 47 (see [page 33](#)).

Bits 7-6	Reserved	--	reserved	
Bit 5	Data Verification	0	CRC16	CRC method is CRC16 Reverse with a seed value of 0.
		1	Checksum	(default)
Bit 4	Protocol	0	Binary	
		1	ASCII	(default)
Bits 3-0	Baud Rate	0	reserved	
		1	115.2k	
		2	reserved	
		3	57.6k	
		4	38.4k	
		5	19.2k	
		6	9600	(default)
		7	4800	
		8	2400	
		9	1200	
		A	600	
		B	300	
		C	reserved	
		D	reserved	
		E	reserved	
		F	reserved	

Serial Protocol Details

Unlike earlier Opto 22 protocols (such as *mistic*), every message in the SNAP I/O serial protocol contains the address of both the source and the destination. A sequence identifier has also been added to keep track of sequences of commands and responses. This provision allows smart devices to perform with reduced communication overhead, resulting in higher performance.

Serial data can be transmitted in binary mode or ASCII mode. ASCII messages contain the same information in the same order as binary messages, but they must start with the > (*greater than*) character and end with a carriage return character. Each byte of ASCII data is transmitted as the ASCII characters represented in the binary message. For example, binary data represented by 41 hex (the character *A*) is transmitted as the two ASCII characters *4* and *1*.

Message Field Definitions—Serial Protocol Packet

Abbrev.	Contents	Definition/Comments
DEST	Destination address of this packet	See “Addressing” on page 11.
SRC	Source address of this packet	For the host source address in an OEM application, use a value of 1. For module addressing, see page 11.
LEN	Total number of bytes following the Length byte, excluding DVF and carriage return	Length calculation starting with Product category and ending with the last byte of the Command/Data fields. For ASCII, divide by 2. The ASCII message is just the binary message (including LEN and DVF) converted to ASCII.
PRC	Product category	Opto 22-defined classification of the message <i>source</i> . See “Product Categories” on page 20.
SEQ	Sequence ID	A unique ID assigned by the host application to identify the order of messages. Possible values: 0–255. Each message transmitted from the host should increment the Sequence ID to distinguish it from the previous message. The response sequence ID identifies the message being responded to.
MST	Message type	Opto 22-defined classification of the message type. See “Message Types” on page 20.
CMD / DATA	Command or Data or both	Command number, data sent or received, or error code. For error codes, see “Error Responses” on page 20.
DVF	Data verification	Data verification field. Checksum requires 1 byte in binary mode or 2 bytes in ASCII mode. CRC requires 2 bytes in binary mode or 4 bytes in ASCII mode. See “About Data Verification” on page 14.

The ASCII version of the message is simply the binary message converted to ASCII format and then encapsulated between the start-of-message character (>) and end-of-message character (carriage return).

About Data Verification

The data verification field (DVF) is calculated on the complete binary message. (For ASCII, the complete binary message including DVF is converted to ASCII.)

In the serial protocol, SNAP modules allow two types of data verification to be used on message transactions, checksum and CRC16.

Calculating a Checksum

Here is a serial binary message sending a Powerup Clear Command (41) to a module at address 85 hex. The last byte is the checksum; it is calculated as shown:

85 01 04 20 01 00 41 EC ←

Add (in hex):
 $85+01+04+20+01+00+41 = EC$
 Take the least significant byte: EC

Calculating a CRC16

CRC16 calculation is more complex. For CRC calculations, the method used is CRC16 Reverse, and the seed (or starting) value is zero. Please see Opto 22 form #270, the *Mistic Analog and Digital Command Manual*, for more information.

Serial Message Examples

Command Message Format

# Bytes:	1	1	1	1	1	1	1	0-1+	1 or 2
Serial binary	DEST	SRC	LEN	PRC	SEQ	MST	DATA		DVF
							CMD	Data	

# Bytes:	1	2	2	2	2	2	2	0-2+	2 or 4	1	
Serial ASCII	>	DEST	SRC	LEN	PRC	SEQ	MST	DATA		DVF	<cr>
								CMD	Data		

NOTE: Do not send another command until you have received a response from the previous command or have waited a reasonable timeout period.

Serial Binary Examples. The following is an example of Command 41 (Powerup Clear) sent to the module at address 85 hex using the serial protocol in binary mode. All numbers are in hex.

DEST	SRC	LEN	PRC	SEQ	MST	CMD	DVF
85	01	04	20	01	00	41	EC

This message is a total of 8 bytes. The checksum was calculated by taking the least significant byte of the sum of the hex values:

$$85h + 01h + 04h + 20h + 01h + 00h + 41h = EC \text{ hex}$$

If this message were viewed as a string of characters, not all of the characters would be printable. It would look something like this:

Character	à	☺	◆		☺		A	∞
Hex	85	01	04	20	01	00	41	EC
Description	à	SOH	EOT	space	SOH	null	A	∞

The next example shows Command 52 (Group Read) used to read the point values on a SNAP-AIV analog input module at address 8A.

DEST	SRC	LEN	PRC	SEQ	MST	CMD	DVF
8A	01	04	20	02	00	52	03

The following example shows how to write values to a SNAP-AOV-25 analog output module at address 8B. Command 53 (Group Write) writes two 16-bit values for each point, but only 12 bits are needed (see [“Resolution and Range” on page 9](#)). This example sets point 0 to 3.8 volts, which is 1556 counts in decimal, or 614 in hex. Point 1 is set to 8 volts, which is 3276 decimal counts, or 0xCCC.

DEST	SRC	LEN	PRC	SEQ	MST	CMD	DATA	DVF
8B	01	08	20	06	00	53	0614 0CCC	FF

Serial ASCII Example. The following example shows Command 41 (Powerup Clear) sent to the module at address 85 hex using the serial protocol in ASCII mode. All numbers are in hex.

	DEST	SRC	LEN	PRC	SEQ	MST	CMD	DVF									
>	8	5	0	1	0	4	2	0	0	1	0	0	4	1	E	C	cr

As you can see, the ASCII command is very similar to the binary command in the previous example. Each nibble of binary data has been converted to an ASCII character, and the prefix (>) and suffix (carriage return) have been added. The resulting message totals 18 bytes.

Response Message Format

# Bytes:	1	1	1	1	1	1	0-1+	1 or 2
Serial binary	DEST	SRC	LEN	PRC	SEQ	MST	DATA	DVF

# Bytes:	1	2	2	2	2	2	2	0-2+	2 or 4	1
Serial ASCII	>	DEST	SRC	LEN	PRC	SEQ	MST	DATA	DVF	<cr>

Serial Binary Examples. The following shows an ACK response packet received after sending Command 41 in the example above. This response uses the serial protocol in binary mode, and all numbers are in hex.

DEST	SRC	LEN	PRC	SEQ	MST	DVF
01	85	03	80	01	01	0B

Again, the checksum is the *least significant byte* of the sum of the hex values:

$$01h + 85h + 03h + 80h + 01h + 01h = 10B \text{ hex} \rightarrow 0B \text{ hex}$$

The next example is a response to the Command 52 sent above, which read the values of the two points on a SNAP-AIV analog input module. The response returns four 16-bit values, but since the module has only two points, only the upper four bytes are significant.

DEST	SRC	LEN	PRC	SEQ	MST	DATA	DVF
01	8A	03	80	01	01	09C4 3F7A 0000 0000	96

The response data indicates that point 0 has a value in counts of 0x09C4, or 2500 decimal, which for a SNAP-AIV module equals 1 volt. (See “Resolution and Range” on page 9.) Point 1 has a value of 0x3F7A, or 16,250 decimal, which equals 6.5 volts.

Serial ASCII Example. The following is an ACK response packet received after sending Command 41 in the example above. This response uses the serial protocol in ASCII mode. All numbers are in hex.

	DEST	SRC	LEN	PRC	SEQ	MST	DVF									
>	0	1	8	5	0	3	8	0	0	1	0	1	0	0	B	cr

ARCNET Protocol

Addressing

Sixteen modules can be addressed per communications link. Every module is automatically assigned an address when it is plugged into a position on the mounting rack.

The address is an offset of 80 hex added to the module's position number on the rack (0 through 15 decimal, as shown on the rack, or 0 through F hex). For example, module 12 (decimal) is C in hex, so its address is 8C. The following table shows the address assigned to each module position number.

Module #	Address (hex)
0	80
1	81
2	82
3	83
4	84
5	85
6	86
7	87

Module #	Address (hex)
8	88
9	89
10	8A
11	8B
12	8C
13	8D
14	8E
15	8F

Point Numbers

Opto 22 point numbers on each module start with zero. The points on a four-channel analog input module, for example, are referred to as point 0, point 1, point 2, and point 3.

Communication

The physical connections required for ARCNET communication are built into the Opto 22 SNAP mounting rack. If you are using a SNAP-ARL-ASDS brain, you need to use the Opto 22 rack in order to communicate with analog and special-purpose modules.

ARCNET Protocol Details

Message Field Definitions—ARCNET Protocol Packet

Abbrev.	Contents	Definition/Comments
SRC	Source address of this packet	For the host source address in an OEM application, use a value of 1. For module addressing, see page 17 .
DEST	Destination address of this packet	See “ Addressing ” on page 17 .
CNT	Count	The number of bytes following this byte, subtracted from 0x100
OSC	OS code	ARCNET Trade Association-defined vendor code (always DA for Opto 22)
PRC	Product category	Opto 22-defined classification of the message <i>source</i> . See “ Product Categories ” on page 20 .
SEQ	Sequence ID	A unique ID assigned by the host application to identify the order of messages. Possible values: 0–255. Each message transmitted from the host should increment the Sequence ID to distinguish it from the previous message. The response sequence ID identifies the message being responded to.
BNK / MST	Bank number and Message type	Upper nibble is bank number (for SNAP modules, always 0); lower nibble is Opto 22-defined classification of the message type. See “ Message Types ” on page 20 .
CMD / SCMD / PRT / DATA	Command, Subcommand, Port, Data, or combination	Command and optional subcommand number, port if required (usually for serial modules), data sent or received, or error code. For error codes, see “ Error Responses ” on page 20 .

ARCNET Message Examples

Command Message Format

# Bytes:	1	1	1	1	1	1	1	1	0–2	0–1	0–1+
ARCNET	SRC	DEST	CNT	OSC	PRC	SEQ	BNK/ MST	DATA			
								CMD	SCMD	PRT	Data

NOTE: Do not send another command until you have received a response from the previous command or have waited a reasonable timeout period.

Command Examples. The following is an example of Command 41 (Powerup Clear) sent to the module at address 0x85 using the ARCNET protocol. All numbers are in hex.

SRC	DEST	CNT	OSC	PRC	SEQ	BNK/ MST	DATA
01	85	FB	DA	20	00	00	41

Here’s an example of Command 63 (Clear Serial Port Receive Buffer) sent to port 1 on the serial module at address 80:

SRC	DEST	CNT	OSC	PRC	SEQ	BNK/ MST	DATA		
							CMD	SCMD	PRT
01	80	F9	DA	20	01	00	63	72	01

Another example: This time Command 53 (Group Write) is used to write to the two points on a SNAP-AOV-25 analog output module at address 8B. This command writes two 16-bit values, but only 12 bits are used for each point (see “Resolution and Range” on page 9). The command sets point 0 to 3.8 volts, which is 1556 counts in decimal, or 614 in hex. Point 1 is set to 8 volts, which is 3276 decimal counts, or 0xCCC.

SRC	DEST	CNT	OSC	PRC	SEQ	BNK/ MST	DATA	
							CMD	DATA
01	8B	F7	DA	20	04	00	53	0614 0CCC

Response Message Format

# Bytes:	1	1	1	1	1	1	1	0–1+
ARCNET	SRC	DEST	CNT	OSC	PRC	SEQ	BNK/ MST	DATA

Response Examples. The following shows the ACK response that might be received after the sample Command 41 (Powerup Clear) is sent using the ARCNET protocol. All numbers are in hex.

SRC	DEST	CNT	OSC	PRC	SEQ	BNK/ MST
85	01	FC	DA	80	00	01

Here is an example of a response to a Command 52 (Group Read) reading the values of the two points on a SNAP-AIV analog input module at address 8A. The response returns four 16-bit values, but since the module has only two points, only the upper four bytes are significant.

SRC	DEST	CNT	OSC	PRC	SEQ	BNK/ MST	DATA
8A	01	F4	DA	80	0A	01	09C4 3F7A 0000 0000

The data indicates that point 0 has a value in counts of 0x09C4, or 2500 decimal, which for a SNAP-AIV module equals 1 volt. (See “Resolution and Range” on page 9.) Point 1 has a value of 0x3F7A, or 16,250 decimal, which equals 6.5 volts.

Global Protocol Definitions

The following tables define Opto 22 product categories, message types, and error responses. These tables apply to both serial and ARCNET protocols.

Product Categories

0 - F (Hex)	Reserved	Numbers used by current products
10 - 1F (Hex)	Brain Boards or Brains	Use 10 for brain boards or brains
20 - 2F (Hex)	Controllers	Use 20 for controllers
30 - 3F (Hex)	Hosts	Use 30 for hosts
40 - 7F	Future expansion	--
80 and above	Modules	Use 80 for modules

Message Types

Type	Description	Byte Definition
0	Send Data Command	Data [252 Bytes Max]
1	Ack	Data [252 Bytes Max]
2	Nack 1-byte error	Error [1 Byte] Data [251 Bytes Max]

NOTE: All binary numeric values are Little Endian (Intel) format. For example, the decimal value 35,243 would be AB 89 in hex.

Error Responses

If an error occurs, the response shows 2 in the MST or BNK/MST byte (see [“Message Types” on page 20](#)) and the error number in the DATA byte. Error numbers are listed below.

Error (hex)	Protocol	Description
01	Serial or ARCNET	Undefined command. This error occurs when the command does not match the situation, for example, if a write command is used with an input module, or if a command 40 is sent to an older module that does not support it. See notes on commands 40 (page 30) and 41 (page 31).
02	Serial only	DVF (checksum or CRC) error This error code indicates a problem with the communications link, which caused a DVF error when a message from the host was sent to the I/O module. DVF errors often occur when the RS-485 network is not wired, terminated, or biased properly. Make sure of the following: <ol style="list-style-type: none"> 1. The link is terminated at the end points and NOT in the middle. 2. The link is biased in only one location, typically at the host end. 3. Twisted-pair cable is used. 4. The link is routed in a daisy-chain fashion, NOT a “star” type distribution.

Error (hex)	Protocol	Description
04	Serial or ARCNET	Device lost power since last message This error indicates that the module has reset. Configuration parameters may have been lost. This error can only be cleared by issuing a Powerup Clear command (40 or 41). See notes on commands 40 (page 30) and 41 (page 31).
05	Serial or ARCNET	Invalid length This error occurs when the module receives a message that does not contain enough data characters for that command.
07	Serial or ARCNET	Invalid data—limits sent are out of range This error indicates that at least one of the data fields in the command message contains an illegal value. Make sure that the values sent are within the range allowed by the configuration for that channel.

Module Types, Channel Modes, and Point Types

Analog Input Modules with Four Points or Less

The following table shows module types and channel modes for SNAP analog input modules with four points or less. All numbers are shown in hex. Defaults are indicated by an asterisk (*). To change channel mode, use command 3A, Set Channel Mode (see page 29).

SNAP Module Part Number	Input Range/Type	Module Type (Hex)	Channel Mode (Hex)
Analog Input Modules			
SNAP-AIMA	2 channels, -20 mA to +20 mA 2 channels, 0–20 mA 2 channels, 4–20 mA	64	22
SNAP-AIMA-i	2 channels, -20 mA to +20 mA 2 channels, 0–20 mA 2 channels, 4–20 mA	22	22
SNAP-AIMA-iSRC	2 isolated channels, -20 mA to +20 mA 2 channels, 0–20 mA 2 channels, 4–20 mA	26	22
SNAP-AIMA-4	4 channels, -20 mA to +20 mA 4 channels, 0–20 mA 4 channels, 4–20 mA	26	22
SNAP-AIMV-4	4 channels, -150 mV to +150 mV * 4 channels, -75 mV to +75 mV	44	20* 30
SNAP-AIMV2-4	4 channels, -50 mV to +50 mV * 4 channels, -25 mV to +25 mV	45	20* 30
SNAP-AITM	2 channels, -150 mV to +150 mV * 2 channels, -75 mV to +75 mV	66	20* 30
SNAP-AITM-i	2 channels, -150 mV to +150 mV * 2 channels, -75 mV to +75 mV	20	20* 30

SNAP Module Part Number	Input Range/Type	Module Type (Hex)	Channel Mode (Hex)
SNAP-AITM-2	2 channels, -50 mV to +50 mV * 2 channels, -25 mV to +25 mV	09	20* 30
SNAP-AITM2-i	2 channels, -50 mV to +50 mV * 2 channels, -25 mV to +25 mV	21	20* 30
SNAP-AIV	2 channels, -10 V to +10 V * 2 channels, -5 V to +5 V	12	22* 32
SNAP-AIV-i	2 channels, -10 V to +10 V * 2 channels, -5 V to +5 V	23	22* 32
SNAP-AIV-4	4 channels, -10 V to +10 V * 4 channels, -5 V to +5 V	41	22* 32
SNAP-AIV2-i	2 channels, -100 to +100 VDC * 2 channels, -50 to +50 VDC	24	22* 32
SNAP-AIV-72 (point 0) SNAP-AIV-72 (point 1)	2 channels, -10 to +10 VDC 2 channels, -100 to +100 VDC	72 72	22 22
SNAP-AIARMS	2 channels, 0 to 10 Amps RMS	71	1A
SNAP-AIVRMS	2 channels, 0 to 250 V RMS	70	1A
SNAP-AICTD	2 channels, Temperature (ICTD)	04	20
SNAP-AICTD-4	4 channels, Temperature (ICTD)	42	20
SNAP-AIRATE	2 channels, 0 to 25,000 Hz	69	20
SNAP-AIR40K-4	4 channels, 0–40 K ohms * 4 channels, 0–20 K ohms 4 channels, 0–10 K ohms 4 channels, 0–5 K ohms	43	10* 20 30 40
SNAP-AIRTD	2 channels, 100 Ohm Pt 3-wire RTD * 100 Ohm Ni 3-wire RTD 120 Ohm Ni 3-wire RTD	10	10
SNAP-AIPM (point 0) SNAP-AIPM (point 1) SNAP-AIPM (point 2) SNAP-AIPM (point 3)	0 to 250 V RMS 0 to 10 Amps RMS True Power Volt-Amps	0A	57 57 Don't set mode
SNAP-AILC	2 channels, -2 to +2 mV/V * 2 channels, -3 to +3 mV/V	0B	8C* 8D
SNAP-AILC-2	2 channels, -4 to +4 mV/V * 2 channels, -3 to +3 mV/V	0C	8C* 8D
SNAP-pH/ORP	2 channels, -1 to +1 VDC (high impedance) * 2 channels, -0.5 to +0.5 VDC (high impedance)	25	20 30

* Default

Analog Input Modules with More than Four Points

The following table shows module types and point types for SNAP analog input modules with more than four points. (Channel modes are not used with these modules.)

All numbers are shown in hex. Defaults are indicated by an asterisk (*). To assign point type, use “Set Point Configuration Command 3C” on page 29).

SNAP Module Part Number	Input Range/Type	Module Type (Hex)	Point Type (Hex)
Analog Input Modules			
SNAP-AIMA-8	8 channels, -20 mA to +20 mA * 8 channels, 0 mA to +20 mA 8 channels, 4 mA to +20 mA	4A	40* 2 3
SNAP-AIMA-32	32 channels, -20 mA to +20 mA * 32 channels, 0 mA to +20 mA 32 channels, 4 mA to +20 mA	4D	40* 2 3
SNAP-AITM-8	8 channels, -75 mV to +75 mV * 8 channels, -50 mV to +50 mV 8 channels, -25 mV to +25 mV 8 channels, type B thermocouple 8 channels, type C thermocouple 8 channels, type D thermocouple 8 channels, type E thermocouple 8 channels, type G thermocouple 8 channels, type J thermocouple 8 channels, type K thermocouple 8 channels, type N thermocouple 8 channels, type R thermocouple 8 channels, type S thermocouple 8 channels, type T thermocouple	4F	44* 9 43 18 20 21 13 1F 5 8 1E 11 17 12
SNAP-AIV-8	8 channels, -10 V to +10 V * 8 channels, -5 V to +5 V	4B	C* B
SNAP-AIV-32	32 channels, -10 V to +10 V * 32 channels, -5 V to +5 V	4E	C* B
SNAP-AICTD-8	8 channels, Temperature (ICTD) *	4C	4*

* Default

Analog Output, Serial, and High-Density Digital Modules

The following table shows module types for analog output modules, serial modules, and high-density digital modules. Module types are shown in hex. (Neither channel modes nor point types are used with these modules.)

Module	Description	Module Type (Hex)
Analog Output Modules		
SNAP-AOA-3	1 channel, 4–20 mA	83
SNAP-AOV-5	1 channel, 0–10 VDC	85
SNAP-AOA-23	2 channels, current loop 4–20 mA	A3
SNAP-AOA-23-iSRC	2 isolated channels, current loop 4–20 mA	B3
SNAP-AOV-25	2 channels, 0–10 VDC	A5
SNAP-AOV-27	2 channels, -10 to +10 VDC	A7
SNAP-AOA-28	2 channels, current loop 0–20 mA	A8
SNAP-AOD-29	2 channels, time-proportional digital output 5–60 VDC	A9
Serial Modules		
SNAP-SCM-232	2 channels, RS-232	F0
SNAP-SCM-485-422	2 channels, RS-485/422 (2-wire or 4-wire)	F1
SNAP-SCM-PROFI	One electrical interface to PROFIBUS DP® networks.	F6
SNAP-SCM-MCH16	1 channel, RS-422 (4-wire) motion control	F8
High-Density Digital Modules		
SNAP-IDC-32	32 channels, digital inputs, 10–32 VDC	E0
SNAP-IDC-16	16 isolated channels, digital inputs, 10–32 VDC/VAC	E5
SNAP-IAC-16	16 isolated channels, digital inputs, 90–140 VAC/VDC	E4
SNAP-IAC-A-16	16 isolated channels, digital inputs, 180–280 VAC/VDC	E3
SNAP-ODC-32-SRC	32 channels, digital outputs, 5–60 VDC load sourcing	E1
SNAP-ODC-32-SNK	32 channels, digital outputs, 5–60 VDC load sinking	E2

4: Commands

Introduction

This chapter starts with a list of all commands and then details individual commands.

In this chapter, only the *data* required for each command is illustrated. For complete packet information and examples, see [“Serial Protocol Details” on page 13](#) or [“ARCNET Protocol Details” on page 18](#).

CAUTION: Notice that some commands have the same command number but apply to different types of modules. For example, command 52 takes a different action depending upon what type of module (analog input, TPO, high-density digital, or serial module) it is sent to. Make sure you address modules carefully, so that commands will have the effect you intend.

IMPORTANT: The commands in this chapter support the following serial communication modules only:

- SNAP-SCM-232 Revision A modules (manufactured in June 2003 or after) with firmware R1.1e or higher. These modules support optional RTS/CTS flow control.
- SNAP-SCM-232 modules manufactured before June 2003 with firmware R1.1o. These modules do *not* support RTS/CTS flow control.
- SNAP-SCM-485-422 modules. (Modules manufactured before June 2003 with the part number SNAP-SCM-485 do not work with the commands in this guide.)

Command List

Commands are shown in numerical order, in hex. Some commands have the same number; be sure to choose the one that applies to your module.

Hex	Serial	ARCNET	Command	Applies to Modules				See
				Analog =<4-ch	Analog >4 ch	HDD*	Serial**	
23		X	Read Number of Received Data Bytes Waiting				X	page 28
32	X	X	Read Channel Mode (Input modules only)	X	X			page 28
3A	X	X	Set Channel Mode (Input modules only)	X	X			page 29
3C	X	X	Set Point Configuration		X			page 29
40	X	X	Powerup Clear—Current Modules (Enables watchdog timer)	X	X	X	X	page 30
41	X	X	Powerup Clear—Legacy Modules (Disables watchdog timer)	X	X	X	X	page 31
42	X	X	Reset	X	X			page 31
42		X	Read Amount of Unused Space in Transmit Buffer				X	page 32
45	X	X	Save Current Module Configuration in EEPROM (Input modules only)	X	X			page 32
46	X	X	Identify Module Type	X	X	X	X	page 33
47	X		Set Serial Port Configuration	X	X	X	X	page 33
48	X		Set Serial Port Response Delay	X	X	X	X	page 34
49	X	X	Read Module Firmware Revision	X	X	X		page 34
52	X		Group Read		X			page 35
52	X	X	Group Read (Input and SNAP-AOD-29 modules only)	X				page 35
52		X	Read Status—Latches Not Cleared			X		page 36
52		X	Receive Serial Data Only				X	page 36
53	X	X	Group Write (Dual-channel output modules only)	X				page 37
53		X	Read Status—Latches Cleared (Input modules only)			X		page 37
54	X	X	Read HDD Counters—Counters Not Cleared			X		page 38
55	X	X	Read HDD Counters—Counters Cleared			X		page 38
55	X	X	Channel Read		X			page 39
56	X	X	Channel Write (Output and SNAP-AOD-29 modules only)	X				page 39
57	X	X	Set TPO Period (SNAP-AOD-29 modules only)	X				page 40
58		X	Write Outputs			X		page 40
58	X	X	Read Status (TPO, Inhibit On/Off) (SNAP-AOD-29 modules only)	X				page 41
63		X	Clear Serial Port Receive Buffer				X	page 41
66		X	Read Serial Port CTS (SCM-232 Rev A modules only)				X	page 42

Hex	Serial	ARCNET	Command	Applies to Modules				See
				Analog =<4-ch	Analog >4 ch	HDD*	Serial**	
66		X	Set Serial Port RTS (SCM-232 Rev A modules only)				X	page 42
66		X	Clear Serial Port RTS (SCM-232 Rev A modules only)				X	page 43
69		X	Read Serial Module Info (SCM-232 Rev A, SCM-485-422 modules only)				X	page 43
71		X	Read Serial Port Configuration				X	page 44
71		X	Write Serial Port Configuration				X	page 45
71		X	Write Serial Port Configuration and Store to Flash				X	page 46
72		X	Receive Line of Serial Data				X	page 46
73		X	Send & Receive Serial Data				X	page 47
74		X	Send Serial Data				X	page 47
*HDD = high-density digital **SNAP-SCM-232 and SNAP-SCM-485-422 modules only								

Command Details

Read Number of Received Data Bytes Waiting

Command 23

(SNAP-SCM-232 and SNAP-SCM-485-422 modules only)

ARCNET protocol only.

This command reads the quantity of bytes waiting in the serial port's receive buffer.

Command Data Required

CMD	1 byte	23
PRT	1 byte	Serial port: 00 for port 0, 01 for port 1

Response Data Received

Data	2 bytes	Number of bytes of received data in the specified serial port's receive buffer (2-byte value in Big Endian format—most significant byte at lowest memory address)
------	---------	---

Read Channel Mode

Command 32

(Analog input modules with four points or less)

For analog input modules with 4 points or less, this command reads the current input channel (point) mode. For possible channel modes, see [“Module Types, Channel Modes, and Point Types” on page 21](#).

To set channel mode, see command 3A on [page 29](#)

Command Data Required

CMD	1 byte	32
Data	1 byte	Channel (point) number

Response Data Received

Data	1 byte	Channel mode value for specified point (See “Module Types, Channel Modes, and Point Types” on page 21 .)
------	--------	--

Set Channel Mode

Command 3A

(Analog input modules with 4 points or less)

For analog inputs for 4 points or less, this command sets the channel (point) mode. For possible modes, see [“Module Types, Channel Modes, and Point Types”](#) on page 21.

To save this information to EEPROM, use command 45.

For analog input modules with more than 4 channels, see [“Set Point Configuration Command 3C,”](#) below.

Command Data Required

CMD		1 byte	3A
Data	MSB	1 byte	Channel (point) number
	LSB	1 byte	Channel mode value

Response Data Received

No response data

Set Point Configuration

Command 3C

(Analog input modules with more than four points)

For analog inputs with more than 4 points, this command configures the specified point. For possible configurations, see [“Analog Input Modules with More than Four Points”](#) on page 23.

If the point configuration data sent with the command is not valid, the default configuration for the module is used. Non-existing channels are ignored.

For a similar command to use with 4-channel analog input modules, see [“Set Channel Mode Command 3A,”](#) above.

Command Data Required

CMD		1 byte	3C
Data	MSB	1 byte	Channel (point) number
	LSB	1 byte	Point configuration (see page 23)

Response Data Received

No response data

Powerup Clear—Current Modules**Command 40**

This initialization command is used to acknowledge that the modules has powered up since the last time the brain communicated with it. This command also enables the command watchdog timer on the module (see notes, below). The command watchdog timer monitors commands received via Arcnet for that module address; if a command is received by the module via Arcnet at least once every 6 seconds, the module will function as normal. However, if the module does not receive a command via Arcnet within a 6 second period, it will assume there is a problem with Arcnet communication, and it initiate an Arcnet bus reconfiguration.

This command must be sent before any other commands will be recognized. This command clears the “Powerup Clear expected” error flag.

Notes: Normal Arcnet command/response times are on the order of milliseconds, so 6 seconds without any Arcnet communication would indicate an abnormal condition.

The command watchdog timer is available on most SNAP I/O modules manufactured after 2004. It is strongly recommended that you use command 40 with modules that support the command watchdog timer. For example, you can initially send command 40 and see if you get a valid response. If you do, then you know that module supports the command watchdog feature. However, you will receive a NAK response if the module does not support this feature. In that case, use command 41 instead.

Command Data Required

CMD	1 byte	40
-----	--------	----

Response Data Received

No response data

Powerup Clear—Legacy Modules

Command 41

This initialization command is used to acknowledge that the module has powered up since the last time the brain communicated with it. This command also disables the command watchdog timer on the module. It should be used only for legacy modules; for newer modules that contain a watchdog, we strongly recommend that you enable the command watchdog feature by using command 40 instead.

A Powerup Clear must be sent before any other commands will be recognized. This command clears the “Powerup Clear expected” error flag. If used on a module with a watchdog timer, it disables the timer.

Note: See notes on command 40 for information about the command watchdog feature.

Command Data Required

CMD	1 byte	41
-----	--------	----

Response Data Received

No response data

Reset

Command 42

(Analog input and output modules only)

This command causes a soft reset of the module’s microprocessor.

Like the automatic reset upon powerup, this Reset command must be followed by a Powerup Clear command (41) to restore normal operation.

Command Data Required

CMD	1 byte	42
-----	--------	----

Response Data Received

No response data

Read Amount of Unused Space in Transmit Buffer Command 42

(SNAP-SCM-232 and SNAP-SCM-485-422 modules only)

ARCNET protocol only.

This command reads the number of bytes of available space in the specified serial port's transmit buffer. This command can be used to prevent overrun of the buffer.

Command Data Required

CMD	1 byte	42
PRT	1 byte	Serial port number: 00 for port 0; 01 for port 1

Response Data Received

Data	4 bytes	Number of bytes that can be added to the serial port's transmit buffer without overrunning it (4-byte value in Big Endian format—most significant byte at lowest memory address)
------	---------	--

Save Current Module Configuration in EEPROM Command 45

(Analog input modules only)

This command saves channel mode (set with command 3A) and serial port settings (command 47) to EEPROM. Settings are then used automatically upon powerup or reset.

Command Data Required

CMD	1 byte	45
-----	--------	----

Response Data Received

No response data

Identify Module Type

Command 46

This command reads a 2-byte identification number. The upper byte identifies the product as a module; the lower byte indicates the module type. For more information, see [“Module Types, Channel Modes, and Point Types”](#) on page 21.

Command Data Required

CMD	1 byte	46
-----	--------	----

Response Data Received

Data	MSB	1 byte	80 = module
	LSB	1 byte	Module type. See “Module Types, Channel Modes, and Point Types” on page 21.

Set Serial Port Configuration

Command 47

Serial protocol only.

This command sets or resets the module’s serial port parameters for communication using the serial protocol. See [“Serial Communication”](#) on page 13.

Command Data Required

CMD	1 byte	47
Data	1 byte	Serial port configuration. See “Serial Communication” on page 13.

Response Data Received

No response data

Set Serial Port Response Delay

Command 48

Serial protocol only.

This command sets a time delay after command execution before a response or ack is returned. This feature may be useful when switching times of modems or if protocol delays need a dead time between serial transmissions.

Command Data Required

CMD	1 byte	48
Data	1 byte	Delay byte in hex (Delay = delay byte * 10 milliseconds)

Response Data Received

No response data

Read Module Firmware Version

Command 49

(All modules except SNAP-SCM-232 and SNAP-SCM-485-422)

This command is used for troubleshooting, usually with the help of Opto 22 Product Support; it reads the version number of the module's firmware.

Command Data Required

CMD	1 byte	49
-----	--------	----

Response Data Received

Data	2 bytes	Firmware version number
------	---------	-------------------------

Group Read**Command 52****(Analog modules with more than four points)**

ARCNET protocol only.

For analog modules with more than four channels, this command returns two 16-bit values, corresponding to points 0–31 on the module. The first 16-bit value, “field terminal counts,” applies to all these modules. The second 16-bit value, “cold junction counts,” applies only to modules used as thermocouples; ignore these bytes for other modules. The data is unmodified from the ADC (analog-to-digital converter—sign plus 15 bits).

Command Data Required

CMD	1 byte	52
-----	--------	----

Response Data Received

Data	MSB	2 bytes	Point 0 field terminal counts
		2 bytes	Point 0 cold junction counts (thermocouples only)
		2 bytes	Point 1 field terminal counts
		2 bytes	Point 1 cold junction counts (thermocouples only)
		:	:
		2 bytes	Point 31 field terminal counts
	LSB	2 bytes	Point 31 cold junction counts (thermocouples only) (Total of 128 bytes for 32 points)

Group Read**Command 52****(Analog 4-channel input and SNAP-AOD-29 TPO modules only)**

For analog input modules, this command returns four 16-bit values, corresponding to points 0–3 on the module. The data is unmodified from the ADC (analog-to-digital converter); however, offset and gain modifications are applied.

For the TPO module, this command returns the TPO and period for both channels.

Command Data Required

CMD	1 byte	52
-----	--------	----

Response Data Received

Data	MSB	2 bytes	Point 0 data (or TPO percent for point 0)
		2 bytes	Point 1 data (or TPO period for point 0)
		2 bytes	Point 2 data (or TPO percent for point 1)
	LSB	2 bytes	Point 3 data (or TPO period for point 1)

Read Status—Latches Not Cleared

Command 52

(High-density digital input modules only)

ARCNET protocol only.

For high-density digital input modules, this command reads status, on latches, and off latches for all points. Latches remain as read; they are not cleared. The command returns four 32-bit values, each corresponding to points 0–31 on the module.

To read and clear latches, see [“Read Status—Latches Cleared Command 53”](#) on page 37.

Command Data Required

CMD	1 byte	52
-----	--------	----

Response Data Received

Data	MSB	4 bytes	Status of all points (1 = On; 0 = Off)
		4 bytes	On-latches set (1 = latch set; 0 = latch clear)
		4 bytes	Off-latches set (1 = latch set; 0 = latch clear)
	LSB	4 bytes	(Future use)

Receive Serial Data

Command 52

(SNAP-SCM-232 and SNAP-SCM-485-422 modules only)

ARCNET protocol only.

This command receives up to the number of serial bytes specified on the specified port, to a maximum of 249. This command does not look for an end-of-line (EOL) character. To receive a line of serial data, see [Command 72](#) (page 46).

Command Data Required

CMD	1 byte	52
PRT	1 byte	Serial port number: 00 for port 0; 01 for port 1
Data	1 byte	Number of bytes to be received (cannot be more than 249)

Response Data Received

Data	0 249 bytes	Serial data from specified port's receive buffer. Up to 249 received data bytes can be included in the response.
------	-------------	--

Group Write

Command 53

(Dual-channel analog output modules only)

This command writes two 16-bit values (12 bits used) to point 0 and point 1 of a dual-channel output module. For examples of how to write data, see [“Serial Message Examples” on page 15](#) or [“ARCNET Message Examples” on page 18](#).

Sending this command to a single-channel output module results in an undefined command error (error 01; see [“Error Responses” on page 20](#)).

Command Data Required

CMD	1 byte	53
Data	MSB 2 bytes	Data to write to point 0
	LSB 2 bytes	Data to write to point 1

Response Data Received

No response data

Read Status—Latches Cleared

Command 53

(High-density digital input modules only)

ARCNET protocol only.

For high-density digital input modules, this command reads status, on latches, and off latches for all points, and it clears all latches after reading. The command returns four 32-bit values, each corresponding to points 0–31 on the module.

To read without clearing latches, see [“Read Status—Latches Not Cleared Command 52” on page 36](#).

Command Data Required

CMD	1 byte	53
-----	--------	----

Response Data Received

Data	MSB 4 bytes	Status of all points (1 = On; 0 = Off)
	4 bytes	On-latches set (1 = latch set; 0 = latch clear)
	4 bytes	Off-latches set (1 = latch set; 0 = latch clear)
	LSB 4 bytes	(Future use)

Read HDD Counters—Counters Not Cleared

Command 54

(High-density digital modules only)

For high-density digital (HDD) modules, this command reads counters for all points on the module but does not clear counters. The command returns two 16-bit values, corresponding to points 31–0 on the module.

To read and clear counters at the same time, see [“Read HDD Counters—Counters Cleared Command 55,”](#) below.

Command Data Required

CMD	1 byte	54
-----	--------	----

Response Data Received

Data	MSB	2 bytes	Point 31 counter
		2 bytes	Point 30 counter
		:	:
	LSB	2 bytes	Point 0 counter

Read HDD Counters—Counters Cleared

Command 55

(High-density digital modules only)

For high-density digital (HDD) modules, this command reads *and clears* counters for all points on the module. The command returns two 16-bit values, corresponding to points 31–0 on the module.

To read counters without clearing them, see [“Read HDD Counters—Counters Not Cleared Command 54,”](#) above.

Command Data Required

CMD	1 byte	55
-----	--------	----

Response Data Received

Data	2 bytes	Point 31 counter
	2 bytes	Point 30 counter
	2 bytes	Point 29 counter
	2 bytes	Point 28 counter
	etc.	etc. to Point 0

Channel Read

Command 55

(Analog modules with more than four points)

For analog modules with more than four points, this command returns two 16-bit values for the specified point on the module. The data is unmodified from the ADC (analog-to-digital converter—sign plus 15 bits); however, offset and gain modifications are applied.

Command Data Required

CMD	1 byte	55
Data	1 byte	Point number (00 to 03 hex)

Response Data Received

Data	2 bytes 2 bytes	Field terminal counts for specified point Cold junction counts for specified point
------	--------------------	---

Channel Write

Command 56

(Analog output and SNAP-AOD-29 TPO modules only)

On an analog output module, this command writes a 16-bit value (12 bits used) to the specified output channel (point) on the module.

On a TPO module, this command writes the TPO “on” time (duty cycle) for the period.

$$\text{OnTime} = \left(\frac{\text{OutputData}}{4095} \right) \times \text{Period}$$

$$\text{OutputData} = 4095 \times \left(\frac{\text{DesiredOnTime}}{\text{Period}} \right)$$

Note: On Time and Period are both in units of seconds.

To set the period, use command 57.

Command Data Required

CMD	1 byte	56
Data	1 byte 2 bytes	Point number (00 or 01) Output data for point

Response Data Received

No response data

Set TPO Period

Command 57

(SNAP-AOD-29 TPO modules only)

This command sets the time-proportional output (TPO) period for a single channel (point) on a SNAP-AOD-29 output module. Use command 56 to set the TPO “on” time.

Command Data Required

CMD	1 byte	57
Data	1 byte 2 bytes	Point number (00 or 01) Value to set the period. See equation below.

Determine the value to set the period as shown below. “Period” in the equation is the desired period in units of seconds.

$$\text{Value} = \left[\left(\frac{\text{Period}}{0.251} \right) - 1 \right]$$

Valid limits: period of 0.251 seconds at 0; 16,449.536 seconds at 65,535.

Response Data Received

No response data

Write Outputs

Command 58

(High-density digital output modules only)

ARCNET protocol only.

For high-density digital output modules, this command writes status to all 32 output points on the module at once. The command uses two masks: one determines which points to write to, and the other determines whether to write “on” or “off.”

NOTE: Sending this command to a 32-channel input module will result in an undefined command error.

Command Data Required

CMD	1 byte	58
Data	4 bytes 4 bytes 4 bytes	Set output points (1 = On; 0 = Off) Points to write to (1 = ignore point; 0 = write to point) Future use

Response Data Received

No response data

Read Status (TPO, Inhibit On/off)**Command 58****(SNAP-AOD-29 TPO modules only)**

This command reads an 8-bit value from the SNAP-AOD-29 TPO module. The 8-bit value contains the output status, the inhibit status, and the output status just prior to inhibit. Only the first six bits are used. See table below.

Command Data Required

CMD	1 byte	58
-----	--------	----

Response Data Received

Data	1 byte	<p>TPO status. Bit functions are:</p> <ul style="list-style-type: none"> 0 TPO 0 LED 1; 1 = Output On 1 TPO 1 LED 2; 1 = Output On 2 Inhibit 0 LED 3; 1 = Inhibit 3 Inhibit 1 LED 4; 1 = Inhibit 4 TPO 0 Status before its inhibit; 1 = Output On 5 TPO 1 Status before its inhibit; 1 = Output On 6–7 Reserved
------	--------	--

Clear Serial Port Receive Buffer**Command 63****(SNAP-SCM-232 and SNAP-SCM-485-422 modules only)****Subcommand 72**

ARCNET protocol only.

This command clears any received data from the specified serial port's receive buffer.

Command Data Required

CMD	1 byte	63
SCMD	1 byte	72
PRT	1 byte	Serial port number: 00 for port 0; 01 for port 1

Response Data Received

No response data

Read Serial Port CTS

Command 66

(SNAP-SCM-232 Rev A modules only)

Subcommand 72-63

ARCNET protocol only.

This command reads the state of the CTS signal for the specified serial port.

NOTE: If this command is used on a serial module with hardware prior to Rev A, an undefined command error is returned. (Older hardware does not support RTS/CTS.)

Command Data Required

CMD	1 byte	66
SCMD	1 byte 1 byte	72 63
PRT	1 byte	Serial port number: 00 for port 0; 01 for port 1

Response Data Received

Data	1 byte	CTS: 01 = asserted; 00 = deasserted
------	--------	-------------------------------------

Set Serial Port RTS

Command 66

(SNAP-SCM-232 Rev A modules only)

Subcommand 73-72

ARCNET protocol only.

This command sets (asserts) the RTS signal for the specified serial port. This command has no effect on RTS if the serial port is configured for hardware flow control.

Command Data Required

CMD	1 byte	66
SCMD	1 byte 1 byte	73 72
PRT	1 byte	Serial port number: 00 for port 0; 01 for port 1

Response Data Received

No response data

Clear Serial Port RTS

Command 66

(SNAP-SCM-232 Rev A modules only)

Subcommand 63-72

ARCNET protocol only.

This command clears (deasserts) the RTS signal for the specified serial port. This command has no affect on RTS if the serial port is configured for hardware flow control.

Command Data Required

CMD	1 byte	66
SCMD	1 byte 1 byte	63 72
PRT	1 byte	Serial port number: 00 for port 0; 01 for port 1

Response Data Received

No response data

Read Serial Module Info

Command 69

(SNAP-SCM-232 Rev A and SNAP-SCM-485-422 modules only)

Subcommand 72

ARCNET protocol only.

This command reads module type and hardware and firmware versions.

NOTE: If this command is used on a serial module with older hardware (SNAP-SCM-232 prior to Rev A or SNAP-SCM-485), an undefined command error is returned.

Command Data Required

CMD	1 byte	69
SCMD	1 byte	72

Response Data Received

Data	1 byte	Module type; see page 24 .
	1 byte	Module subtype = 01 for Revision A
	4 bytes	Hardware revision date. Format is DDMMYYYY in hex (1B0A07D4 = 27 October 2004)
	4 bytes	Loader version number in the format MMmmTTbb (in hex), where: MM = Major version mm = Minor version TT = Type (00 = alpha; 01 = beta; 02 = release) bb = Build number (00–FF) Example: 0103020E = R1.3o
	4 bytes	Firmware version number in same format as loader revision

Read Serial Port Configuration

Command 71

(SNAP-SCM-232 and SNAP-SCM-485-422 modules only)

Subcommand 67

ARCNET protocol only.

This command reads the port configuration for all serial ports on the module.

Command Data Required

CMD	1 byte	71
SCMD	1 byte	67

Response Data Received

Data (total 51 bytes)	4 bytes	Port 0: Data rate, bps (32-bit integer in Big Endian format)
	1 byte	Port 0: Parity. N = none, O = odd, E = even, M = mark, S = space
	1 byte	Port 0: Number of data bits (5–8)
	1 byte	Port 0: Stop bits (1, 2)
	1 byte	Port 0: Handshake. 0 = none, 1 = hardware (RTS/CTS full duplex flow control)
	1 byte	Port 0: Port greeting enabled on powerup. 1 = yes, 0 = no
	4 bytes	Port 1: Data rate, bps (32-bit integer in Big Endian format)
	1 byte	Port 1: Parity. N = none, O = odd, E = even, M = mark, S = space
	1 byte	Port 1: Number of data bits (5–8)
	1 byte	Port 1: Stop bits (1, 2)
	1 byte	Port 1: Handshake. 0 = none, 1 = hardware (RTS/CTS full duplex flow control)
	1 byte	Port 1: Port greeting enabled on powerup. 1 = yes, 0 = no
	5 bytes	Port 0: End-of-line terminating character list. Contains a null-terminated string of up to 4 EOL terminating characters.
	1 byte	Port 0: Filter out sequential duplicate lines. 1 = yes, 0 = no
	10 bytes	Port 0: Reserved
	5 bytes	Port 1: End-of-line terminating character list. Contains a null-terminated string of up to 4 EOL terminating characters.
	1 byte	Port 1: Filter out sequential duplicate lines. 1 = yes, 0 = no
	10 bytes	Port 1: Reserved
1 byte	Mode. 0 = 2-wire, 1 = 4-wire (SCM-485-422 modules only)	

Write Serial Port Configuration

Command 71

(SNAP-SCM-232 and SNAP-SCM-485-422 modules only)

Subcommand 6E

ARCNET protocol only.

This command writes port configuration to all serial ports on the module. Configuration is not stored to flash; to write the configuration and store it to flash, use command 71 with subcommand 73 (page 46).

Command Data Required

CMD	1 byte	71
SCMD	1 byte	6E
Data (total 51 bytes)	4 bytes	Port 0: Data rate, bps (32-bit integer in Big Endian format)
	1 byte	Port 0: Parity. N = none, O = odd, E = even, M = mark, S = space
	1 byte	Port 0: Number of data bits (5–8)
	1 byte	Port 0: Stop bits (1, 2)
	1 byte	Port 0: Handshake. 0 = none, 1 = hardware (RTS/CTS full duplex flow control)
	1 byte	Port 0: Port greeting enabled on powerup. 1 = yes, 0 = no
	4 bytes	Port 1: Data rate, bps (32-bit integer in Big Endian format)
	1 byte	Port 1: Parity. N = none, O = odd, E = even, M = mark, S = space
	1 byte	Port 1: Number of data bits (5–8)
	1 byte	Port 1: Stop bits (1, 2)
	1 byte	Port 1: Handshake. 0 = none, 1 = hardware (RTS/CTS full duplex flow control)
	1 byte	Port 1: Port greeting enabled on powerup. 1 = yes, 0 = no
	5 bytes	Port 0: End-of-line terminating character list. Contains a null-terminated string of up to 4 EOL terminating characters.
	1 byte	Port 0: Filter out sequential duplicate lines. 1 = yes, 0 = no
	10 bytes	Port 0: Reserved
5 bytes	Port 1: End-of-line terminating character list. Contains a null-terminated string of up to 4 EOL terminating characters.	
1 byte	Port 1: Filter out sequential duplicate lines. 1 = yes, 0 = no	
10 bytes	Port 1: Reserved	
1 byte	Mode. 0 = 2-wire, 1 = 4-wire (SCM-485-422 modules only; has no effect on SCM-232)	

Response Data Received

No response data

Write Serial Port Configuration and Store to Flash Command 71

(SNAP-SCM-232 and SNAP-SCM-485-422 modules only)

Subcommand 73

ARCNET protocol only.

This command writes port configuration to all serial ports on the module and stores configuration to flash. If you don't want to store to flash, use command 71 with subcommand 6E ([page 45](#)).

Command Data Required

CMD	1 byte	71
SCMD	1 byte	73
Data	51 bytes	Same details as command 71, subcommand 6E (see page 45)

Response Data Received

No response data

Receive Line of Serial Data Command 72

(SNAP-SCM-232 and SNAP-SCM-485-422 modules only)

ARCNET protocol only.

This command receives one line of data (or 249 bytes, whichever is shorter) from the specified serial port. A line ends when one of the configured end-of-line (EOL) terminating characters for the serial port appears.

If an EOL character is found in data received by the serial port, all data bytes up to the EOL character are returned in the response. The EOL character itself is thrown away. This command cannot return more than 249 bytes of received data. If an EOL character is not detected within 249 bytes, the first 249 bytes received are returned. If there are less than 249 bytes and no EOL, the response comes back immediately with no characters. (To retrieve data in this situation, use Command 52, Receive Serial Data.)

Command Data Required

CMD	1 byte	72
PRT	1 byte	Serial port number: 00 for port 0; 01 for port 1

Response Data Received

Data	0 to 249 bytes	One line of data from the serial port's receive buffer, ending at EOL character or at 249 bytes, whichever is shorter
------	----------------	---

Send & Receive Serial Data

Command 73

(SNAP-SCM-232 and SNAP-SCM-485-422 modules only)

ARCNET protocol only.

This command transmits up to 247 data bytes out the specified serial port and immediately returns any data in the serial port's receive buffer in response. This command is the same as using command 74, Send Serial Data Only (page 47) followed by command 52, Receive Serial Data Only (page 36), but it is more efficient since it requires only one command/response transaction.

Command Data Required

CMD	1 byte	73
PRT	1 byte	Serial port number: 00 for port 0; 01 for port 1
Data	0 to 247 bytes	Data to transmit out serial port. Maximum 247 bytes.

Response Data Received

Data	1 byte to 249 bytes	Serial data from specified port's receive buffer. Up to 249 received data bytes can be included in the response.
------	---------------------	--

Send Serial Data

Command 74

(SNAP-SCM-232 and SNAP-SCM-485-422 modules only)

ARCNET protocol only.

This command transmits up to 247 data bytes out the specified serial port.

To transmit and receive in the same command, use command 73, Send & Receive Serial Data.

Command Data Required

CMD	1 byte	74
PRT	1 byte	Serial port: 00 for port 0, 01 for port 1
Data	1 byte to 247 bytes	Data to transmit out serial port. Maximum 247 bytes.

Response Data Received

No response data

Index

A

- addressing modules
 - ARCNET protocol, 17
 - serial protocol, 11
- analog module
 - channel mode, 21, 23
 - configuring points, 29
 - description, 1
 - electrical specifications, 8
 - input module types, 21, 23
 - mechanical specifications, 5
 - output module types, 24
 - reading, 39
 - reading points, 35
 - resolution, 9
 - scaling, 9
 - wiring, 8
 - writing to output, 37, 39
- ARCNET protocol, 17
 - communication, 17
 - message examples, 18
 - message field definitions, 18
- ASCII, 13, 14
 - message format, 16
 - response format, 16

B

- baud rate, 13
- binary, 13
 - format of numeric values, 20
 - message format, 15
 - response format, 16

BNK/MST, 20

C

- categories for products, 20
- channel mode, 21, 23
 - reading, 28
 - setting, 29
- channel numbering, 12, 17
- Channel Read, 39
- Channel Write, 39
- checksum, 13, 14
 - calculating, 14, 15
 - error, 20
- Clear Serial Port Receive Buffer, 41
- Clear Serial Port RTS, 43
- command
 - list of all commands, 26
 - message format (ARCNET protocol), 18
 - message format (serial protocol), 15
- communication
 - ARCNET protocol, 17
 - default serial port settings, 13
 - serial protocol, 11
 - with modules, 2
- configuring
 - point type, 29
- configuring point type, 23
- counters, 38
 - clearing, 38
- CRC16, 13, 14, 15
- CTS
 - modules supported, 9
 - reading, 42

D

- data sheets for modules, 1
- data verification, 13
 - serial protocol, 14
- digital module
 - description, 1
 - electrical specifications, 7
 - mechanical specifications, 5
 - reading & clearing HDD counters, 38
 - reading & clearing HDD latches, 37
 - reading HDD counters, 38
 - reading HDD latches, 36
 - wiring, 7
- disabling watchdog timer, 31
- duty cycle, 39
- DVF, 14
 - calculation example, 15
 - error, 20

E

- EEPROM, saving to, 32, 46
- electrical specifications, 7
- enabling watchdog timer, 30, 31
- error numbers, 20
- error responses, 20
- example
 - ARCNET protocol message, 18
 - reading input (ARCNET protocol), 19
 - reading input (serial protocol), 16
 - serial protocol message, 15
 - writing to output (ARCNET protocol), 19
 - writing to output (serial protocol), 15

F

- field definitions
 - ARCNET protocol, 18
 - serial protocol, 14
- firmware, reading version, 34, 43
- flash memory
 - saving to, 32
 - storing serial module configuration, 46
- format

- ARCNET protocol message, 18
- binary numeric values, 20
- serial protocol message, 15

G

- Group Read, 35
- Group Write, 37

H

- hardware
 - reading version, 43
 - serial modules supported, 9
- help
 - Product Support, 3
- high scale, 9
- high-density digital module
 - description, 1
 - module type, 24
 - reading & clearing counters, 38
 - reading & clearing latches, 37
 - reading counters, 38
 - reading latches, 36
 - reading status, 36, 37
 - writing outputs, 40

I

- Identify Module Type, 33
- inhibit status (TPO), 41
- input
 - reading values, ARCNET protocol example, 19
 - reading values, serial protocol example, 16
- interface
 - electrical, 7
 - mechanical, 5

L

- latches, 36, 37
- Linux brain, 2, 17
- list of commands, 26
- low scale, 9

M

- mechanical specifications, 5
- message field definitions
 - ARCNET protocol, 18
 - serial protocol, 14
- message types, 20
- module
 - addressing for ARCNET protocol, 17
 - addressing for serial protocol, 11
 - choosing modules, 1
 - communicating with, 2
 - mounting rack, 5
 - power requirements, 10
 - types, 1, 21
 - identifying, 33
- mounting rack, 5
- MST, 20

O

- Opto 22 Product Support, 3
- output
 - writing values to, ARCNET protocol example, 19
 - writing values to, serial protocol example, 15
- over range, 9

P

- packet
 - ARCNET protocol, 18
 - serial protocol, 14
- point
 - configuring, 23
 - numbering, 12, 17
 - types, 23
- port settings for serial protocol, 13
- power requirements for modules, 10
- Powerup Clear, 30, 31
- PRC, 20
- product categories, 20
- Product Support, 3
- protocol
 - ARCNET, 17
 - choosing, 2
 - serial, 11

R

- rack, 5
- range, 9
- Read Amount of Unused Space in Transmit Buffer, 32
- Read and Clear HDD Counters, 38
- Read Channel Mode, 28
- Read HDD Counters, 38
- Read Module Firmware Version, 34
- Read Number of Received Data Bytes Waiting, 28
- Read Serial Module Info, 43
- Read Serial Port Configuration, 44
- Read Serial Port CTS, 42
- Read Status (TPO, Inhibit On/Off), 41
- Read Status—Latches Cleared, 37
- Read Status—Latches not Cleared, 36
- reading analog input points, 16, 19, 35, 39
- Receive Line of Serial Data, 46
- Receive Serial Data, 36
- Reset, 31
- resolution, 9
- response
 - errors, 20
 - message format (ARCNET protocol), 19
 - message format (serial protocol), 16
- RTS, 43
 - modules supported, 9
 - setting, 42

S

- Save Current Module Configuration in EEPROM, 32
- scaling, 9
- Send & Receive Serial Data, 47
- Send Serial Data, 47
- serial communication module
 - buffer overrun, 32
 - clearing receive buffer, 41
 - clearing RTS, 43
 - description, 1
 - module types, 24
 - modules supported, 9
 - reading bytes waiting, 28
 - reading configuration, 44
 - reading CTS, 42

- reading hardware and firmware version, 43
- receiving data, 36, 46, 47
- sending data, 47
- setting RTS, 42
- writing configuration, 45, 46

serial protocol, 11

- ASCII, 13
- ASCII examples, 16
- binary, 13
- binary examples, 15, 16
- communication settings, 13
- data verification, 14
- message examples, 15
- message field definitions, 14
- setting port configuration, 33, 34

Set Channel Mode, 29

Set Point Configuration, 29

Set Serial Port Configuration, 33

Set Serial Port Response Delay, 34

Set Serial Port RTS, 42

Set TPO Period, 40

SNAP-ARL-ASDS brain, 17

SNAP-SCM-232 serial module, 9

SNAP-SCM-485 serial module, 9

SNAP-SCM-485-422 serial module, 9

special-purpose module

- mechanical specifications, 5
- module types, 24

specifications

- electrical, 7

- mechanical, 5
- module data sheets, 1
- power requirements, 10

T

- technical support, 3
- TPO, 35, 39, 40, 41
- troubleshooting
 - error responses, 20
 - Product Support, 3
- types of messages, 20

U

- under range, 9

W

- watchdog timer
 - disabling, 31
 - enabling, 30
- watchdog timer, enabling, 31
- wiring, 7
 - module addresses for serial protocol, 12
- Write Outputs, 40
- Write Serial Port Configuration, 45
- Write Serial Port Configuration and Store to Flash, 46
- writing to analog output, 37, 39