

DRAFT

B1 AND B2 USER'S GUIDE

Form 1574-121113—November 2012

OPTO 22

43044 Business Park Drive • Temecula • CA 92590-3614
Phone: 800-321-OPTO (6786) or 951-695-3000
Fax: 800-832-OPTO (6786) or 951-695-2712
www.opto22.com

Product Support Services

800-TEK-OPTO (835-6786) or 951-695-3080
Fax: 951-695-3017
Email: support@opto22.com
Web: support.opto22.com

B1 and B2 User's Guide
Form 1574-121113—November 2012

Copyright © 1997–2012 Opto 22.
All rights reserved.
Printed in the United States of America.

The information in this manual has been checked carefully and is believed to be accurate; however, Opto 22 assumes no responsibility for possible inaccuracies or omissions. Specifications are subject to change without notice.

Opto 22 warrants all of its products to be free from defects in material or workmanship for 30 months from the manufacturing date code. This warranty is limited to the original cost of the unit only and does not cover installation, labor, or any other contingent costs. Opto 22 I/O modules and solid-state relays with date codes of 1/96 or later are guaranteed for life. This lifetime warranty excludes reed relay, SNAP serial communication modules, SNAP PID modules, and modules that contain mechanical contacts or switches. Opto 22 does not warrant any product, components, or parts not manufactured by Opto 22; for these items, the warranty from the original manufacturer applies. These products include, but are not limited to, OptoTerminal-G70, OptoTerminal-G75, and Sony Ericsson GT-48; see the product data sheet for specific warranty information. Refer to Opto 22 form number 1042 for complete warranty information.

Wired+Wireless controllers and brains and N-TRON wireless access points are licensed under one or more of the following patents: U.S. Patent No(s). 5282222, RE37802, 6963617; Canadian Patent No. 2064975; European Patent No. 1142245; French Patent No. 1142245; British Patent No. 1142245; Japanese Patent No. 2002535925A; German Patent No. 60011224.

Opto 22 FactoryFloor, Optomux, and Pamux are registered trademarks of Opto 22. Generation 4, ioControl, ioDisplay, ioManager, ioProject, ioUtilities, *mistic*, Nvio, Nvio.net Web Portal, OptoConnect, OptoControl, OptoDataLink, OptoDisplay, OptoEMU, OptoEMU Sensor, OptoEMU Server, OptoOPCServer, OptoScript, OptoServer, OptoTerminal, OptoUtilities, PAC Control, PAC Display, PAC Manager, PAC Project, SNAP Ethernet I/O, SNAP I/O, SNAP OEM I/O, SNAP PAC System, SNAP Simple I/O, SNAP Ultimate I/O, and Wired+Wireless are trademarks of Opto 22.

ActiveX, JScript, Microsoft, MS-DOS, VBScript, Visual Basic, Visual C++, Windows, and Windows Vista are either registered trademarks or trademarks of Microsoft Corporation in the United States and other countries. Linux is a registered trademark of Linus Torvalds. Unicenter is a registered trademark of Computer Associates International, Inc. ARCNET is a registered trademark of Datapoint Corporation. Modbus is a registered trademark of Schneider Electric. Wiegand is a registered trademark of Sensor Engineering Corporation. Nokia, Nokia M2M Platform, Nokia M2M Gateway Software, and Nokia 31 GSM Connectivity Terminal are trademarks or registered trademarks of Nokia Corporation. Sony is a trademark of Sony Corporation. Ericsson is a trademark of Telefonaktiebolaget LM Ericsson. CompactLogix, MicroLogix, SLC, and RSLogix are trademarks of Rockwell Automation. Allen-Bradley and ControlLogix are registered trademarks of Rockwell Automation. CIP and EtherNet/IP are trademarks of ODVA.

All other brand or product names are trademarks or registered trademarks of their respective companies or organizations.

Table of Contents

OPTO 22

Chapter 1: Welcome	1
Overview	1
What's In This Guide?	2
Document Conventions	2
For Help	3
Chapter 2: Introduction	5
About Optomux	5
System Configuration	6
Physical Layout	6
Communications	6
Modular Construction	6
Wiring	7
Data Transmission	7
System Throughput	7
Features	8
Digital Optomux	8
Latched Inputs	8
Time Delays	8
Pulse Generation	9
Event Counting	9
Pulse Duration Timers	9
Analog Optomux	9
Analog Input Averaging	9
High/Low Limit Testing	9
Output Waveform Generation	9
High/Low Value Recording	9
Gain and Offset Calculation	9
Summary	10
Chapter 3: Installation and Wiring	11
Physical Installation	11
Mounting	11

DRAFT

Communications Wiring	11
Host to First Optomux Unit	11
Unit to Unit	12
Installing Digital I/O Modules	13
Installing Analog I/O Modules	14
Power Requirements	15
Connecting the Power Supply	15
Third-Party Power Supply Vendors	17
Brain Board Mounting	18
Selecting the Jumpers	19
Group A Jumpers	19
Group B Jumpers	19
Baud Rate Selection	20
Protocol Selection	20
Address Selection	20
Accessories	22
Power Supplies	22
Adapter Cards	22
Appendix A: Surge Protection	23
Surge Protection For RS-422/485 Communication Links	23
Appendix B: Troubleshooting	25
Troubleshooting Questions and Answers	25

1: Welcome

Overview

The B1 digital and B2 analog Optomux brain boards are intelligent digital processors that operate as slave devices to a host computer. Each brain board contains a microprocessor that provides the necessary intelligence to communicate with a host computer and also perform control functions at each channel of I/O.

B1 and B2 brain boards communicate with the host device using the Optomux protocol over an RS-422/485 serial link, providing low-cost distributed access to both digital and analog I/O. Using a simple serial port with an RS-485 converter, up to 4095 I/O points can be accessed over a distance of several thousand feet at moderate speeds with high reliability.

NOTE: B1 and B2 brain boards offer serial communications only. For new installations or replacement boards, E1 and E2 brain boards are recommended instead. E1s and E2s are designed as drop-in replacements for B1s and B2s, but they also offer additional network and protocol options. E1s and E2s can communicate over both serial and Ethernet networks using Optomux, and simultaneously communicate using Modbus/TCP and the OptoMMP memory-mapped protocol over Ethernet. In addition, E1s and E2s can be used with Opto 22's ioProject software suite. See form #1546, the E1 and E2 Data Sheet, for more information.

B1 Digital Brain Board

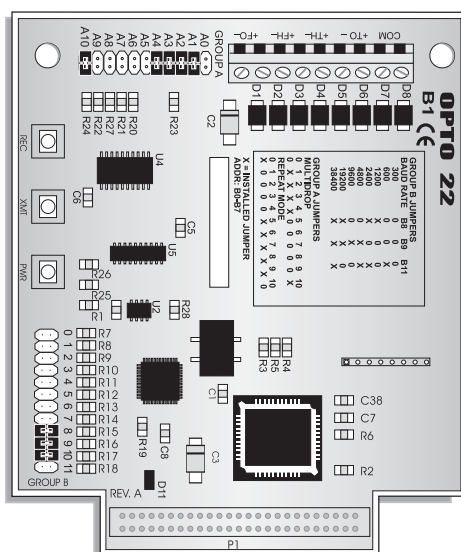

B2 Analog Brain Board

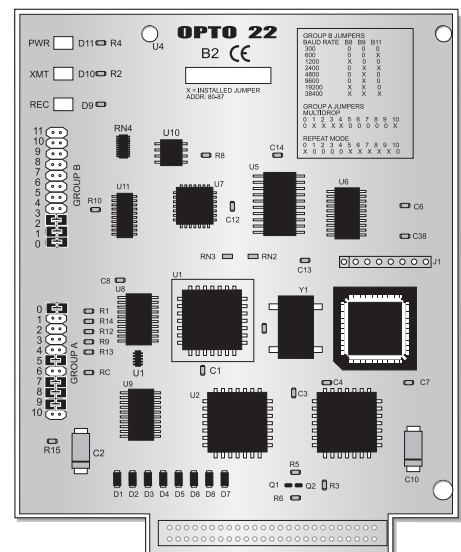

What's In This Guide?

This guide includes the following chapters:

Chapter 1: Welcome—This chapter.

Chapter 2: Introduction—Overview of Optomux protocol and hardware.

Chapter 3: Installation and Wiring—Optomux unit communication wiring, power wiring, installation, and jumpers.

Chapter A: Surge Protection—Information on getting surge protection for RS-422/485 communication links.

Chapter B: Troubleshooting—Troubleshooting Questions and Answers.

“Product Support”—information on how to get help from Opto 22.

Document Conventions

- **Bold** typeface indicates text to be typed. Unless otherwise noted, such text may be entered in upper or lower case. (Example: “At the DOS prompt, type **cd \windows.**”)
- *Italic* typeface indicates emphasis and is used for book titles. (Example: “See the *OptoControl User's Guide* for details.”)
- File names appear in all capital letters. (Example: “Open the file TEST1.TXT.”)
- Key names appear in small capital letters. (Example: “Press SHIFT.”)
- Key press combinations are indicated by hyphens between two or more key names. For example, SHIFT-F1 is the result of holding down the SHIFT key, then pressing and releasing the F1 key. Similarly, CTRL-ALT-DELETE is the result of pressing and holding the CTRL and ALT keys, then pressing and releasing the DELETE key.
- “Press” (or “click”) means press and release when used in reference to a mouse button.
- Menu commands are sometimes referred to with the Menu > Command convention. For example, “Select File > Run” means to select the Run command from the File menu.
- Numbered lists indicate procedures to be followed sequentially. Bulleted lists (such as this one) provide general information.

DRAFT

For Help

If you have problems installing or using a B1 or B2 brain and cannot find the help you need in this guide, contact Opto 22 Product Support.

Phone: 800-TEK-OPTO (800-835-6786)
951-695-3080
(Hours are Monday through Friday,
7 a.m. to 5 p.m. Pacific Time)

NOTE: Email messages and phone calls to Opto 22 Product Support are grouped together and answered in the order received.

Fax: 951-695-3017

Email: support@opto22.com

Opto 22 website: www.opto22.com

When calling for technical support, be prepared to provide the following information about your system to the Product Support engineer:

- Software and version being used
- Controller firmware version
- PC configuration
- A complete description of your hardware and operating systems, including:
 - jumper configuration
 - accessories installed (such as expansion daughter cards)
 - type of power supply
 - types of I/O units installed
 - third-party devices installed (e.g., barcode readers)
- Specific error messages seen

DRAFT

DRAFT

2: Introduction

About Optomux

Optomux is a protocol used by a family of intelligent digital and analog I/O (input/output) units that operate as slave devices to a host computer.

An Optomux I/O unit is a 4-, 8-, or 16-point assembly that accommodates optically-isolated analog or digital I/O modules. Each Optomux I/O unit consists of a removable brain board and an I/O mounting rack. The removable brain board contains a microprocessor which communicates with the host computer and controls the plug-in I/O modules located on the I/O mounting rack.

There are two types of Optomux units: analog and digital. Any combination of analog I/O modules may be plugged into an analog Optomux unit and likewise, any combination of digital I/O modules may be plugged into a digital rack. Analog and digital Optomux units from the SNAP, brick, and Classic rack families can then be combined on the same serial link, providing endless combinations of analog and digital I/O points.

Optomux I/O units communicate with the host computer over an RS-485 serial communications link. The serial data link is composed of two twisted pairs and a ground (5 wires) that connect to each Optomux IO unit. It is possible to communicate with up to 256 individual units on a single serial data link for a total of 4,096 digital and analog I/O points. This requires configuring all units (B1's and B2's) in Repeat mode. However, this can also be accomplished with all units in Multidrop mode, using a repeater (AC30) after every 32 nodes.

The RS-485 serial data link offers excellent noise immunity and long cable lengths. This can dramatically reduce wiring costs by eliminating the need for bringing large bundles of field wiring back to a central control location. Optomux units can be located where the actual control is needed.

The Optomux protocol and driver are described in form #1572, the Optomux Protocol Guide. This guide is available on our Web site, www.opto22.com. The easiest way to find it is to search on the form number.

DRAFT

System Configuration

Physical Layout

The high cost of electrical wiring and the noise susceptibility of analog signals make it desirable to place the control or monitoring point as close to the controlled device as possible. Optomux offers design flexibility, with as few as 4 points or as many as 4,096 points in one physical location. Each Optomux IO unit must be assigned its own unique address, 0 through 255.

Considerable installation savings and improved system performance can be realized by placing the control point (Optomux) close to the controlled device. The serial data link between adjacent Optomux IO units consists of two twisted pairs and a common which makes it practical to have an Optomux located at each machine on a factory floor, at each heating or air conditioning unit in an energy management application, or at each instrument in a data acquisition environment.

Communications

Optomux I/O units can be configured to operate in multidrop or repeat mode via jumpers located on each Optomux protocol brain board. For more information on communications, wiring, and system layout, please refer to the individual data sheet for Optomux protocol brain boards.

Modular Construction

Each Optomux unit is composed of two components, a brain board and a module mounting rack. For example, the B1 connects to the rack via a 50-pin header connector. The following figure shows a typical B1/mounting rack combination assembly.

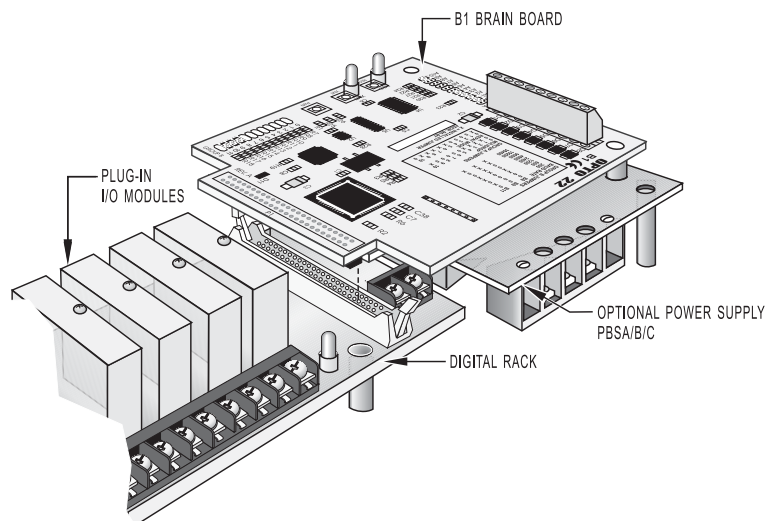

Figure 1-1: Brain Board and Rack Assembly

DRAFT

Wiring

Inputs and outputs are connected to the Optomux mounting rack via an industrial barrier strip with integral cable clamp for each terminal. Spade lugs, other wire terminations, bare wires, and tinned wires are all readily accepted. Serial link connections and power connections are also made via screw terminals.

Data Transmission

Optomux supports 8 baud rates (300, 600, 1,200, 2,400, 4,800, 9,600, 19.2K, and 38.4K) which are selectable via jumpers located on the Optomux unit. Selection of baud rate often depends upon the capabilities of the host port. Many host computers are limited to 9,600. Modems and radio links usually operate at either 300 or 1,200 baud. System throughput is increased by using the fastest available baud rate.

Optomux is capable of using two types of message protocols. The 2-pass protocol is intended for use during normal operation. This protocol requires the transmission of two messages on the serial link every time a command is executed. The host sends a command to an Optomux unit and then receives a response message acknowledging successful execution of the command along with any requested data, or an error message indicating that the Optomux detected an error in the command message and was unable to execute it.

A 4-pass protocol is also available. This protocol is sometimes useful during initial setup and installation because it allows the host to examine and display the command message that Optomux received. The command message is echoed back to the host by Optomux for verification, before it can be executed. After the host verifies that the two messages are identical, an execute command gives Optomux the go ahead, the required action is performed, and any requested data is returned.

To ensure secure data transmission, every Optomux command message, and every response from Optomux which contains data, includes a calculated checksum. Optomux never executes a command containing a checksum error.

System Throughput

In most control applications, some points need to be updated more frequently than others. This section will help you estimate the minimum timing between successive events or transactions.

The total time required to complete an Optomux instruction is approximately equal to the transmission time of all the characters in the instruction, plus all the characters in the response. The time required for digital Optomux units to respond to a command is typically less than 1 millisecond. Typical analog Optomux response times are from 3 to 7 milliseconds.

A total of 15 characters are required to read the ON/OFF status of all 16 positions on a digital Optomux unit. The command sent from the host requesting the status consist of 7 characters; the response from Optomux consists of 8 characters. The following table shows system throughput, assuming that it takes 1 millisecond for Optomux to respond to the host command.

Reading the values of 16 analog inputs on an analog Optomux unit requires a total of 79 command/response characters. The command sent by the host consists of 11 characters; the response from Optomux consists of 68 characters. If we assume a response time of 7 milliseconds, the following table shows system throughput based upon reading all 16 positions per transaction.

Baud Rate	ms/ Character	Char/ Second	Digital Positions/ Second	Analog Positions/ Second
300	33.3	30	32	6
1,200	8.5	120	124	24
9,600	1.0	1,000	1,000	186
19.2K	0.5	2,000	1,882	344
38.4K	0.25	4,000	3,368	598

Table 1-1: Optomux System Throughput

Features

System performance and throughput are increased by allowing the Optomux I/O unit to do as much processing as possible, thereby reducing serial line activity and host computer processing. The following summary of Optomux capabilities will help you determine which tasks can be performed by the B1 or B2 I/O unit.

Digital Optomux

In addition to ON/OFF control, B1 Optomux units provide:

Latched Inputs

Any or all input positions can be used to record momentary events by functioning as latches. Each input position can be configured by host command to latch on either OFF-to-ON or ON-to-OFF transitions. The host computer can recall and/or clear the status of these latches.

Time Delays

Any or all output positions can function in time delay mode. Outputs can be set to operate with four types of delays.

- Delay before turning OFF
- Delay before turning ON
- Pulse ON
- Pulse OFF

Time delays are programmable with a resolution of 10 milliseconds.

DRAFT

Pulse Generation

The B1 can be instructed to output a specific number of pulses (with programmable period) at any output position. Continuous square waves can also be generated.

Event Counting

Any or all input positions can function as event counters to return a count of external events. The count ranges from 0 to 65,535. Each of the event counters can be individually read, stopped, and cleared. Frequencies of up to 400 Hz with a minimum duty cycle of 50 percent can be counted.

Pulse Duration Timers

Any or all of the input positions can function as pulse duration timers. Either ON or OFF pulses can be timed with a resolution of 10 milliseconds.

Analog Optomux

In addition to simple input and output, B2 Optomux units perform:

Analog Input Averaging

The B2 can be instructed to average the values of successive readings.

High/Low Limit Testing

Input ranges can be established for input positions, causing flags to be set when either high or low limits are exceeded. These flags can be read and/or cleared by the host computer at any time.

Output Waveform Generation

Square waves, triangle waves, and ramps can be generated at any of the 16 module positions with programmable rates.

High/Low Value Recording

The B2 can be instructed to remember the highest and lowest readings at input positions for recall by the host computer.

Gain and Offset Calculation

The B2 can be instructed to calculate and set offsets and gain coefficients for input positions allowing for easy calibration under software control.

Summary

In laying out your installation, plan to route the RS-422 data link cable to all points where you need to install Optomux I/O units now and to all points where you may need control in the future.

Supply +5 VDC to each Optomux location, preferably with a local power supply. For repeat mode systems, make it difficult for anyone to accidentally remove the power or data cables from the repeat mode Optomux units. For analog Optomux units, supply +15 and -15 VDC to power the analog I/O modules.

Choose a baud rate and protocol compatible with your host computer, and make this information available to the hardware installer. The installer will need it to set the jumpers on each controller.

Assign a unique address to each controller. Addresses may appear in any order from beginning to end of the data link; however, every address must be unique. No two controllers may share the same address. There is no requirement for consecutive addresses. The entire range of addresses may be used. Try to relate the address to a location or function.

Outline the functions of the application software. Take advantage of the B1's and B2's processing capability to off-load host computer processing time and to reduce data link activity.

DRAFT

3: Installation and Wiring

Physical Installation

Mounting

The B1 or B2 Optomux unit can be mounted in any attitude on any flat surface. The mounting rack and removable brain board portion of the Optomux unit are supplied with permanently-attached standoffs. All of the standoffs should be secured for maximum physical strength. Be sure to leave sufficient space between adjacent controllers for the I/O wiring.

To ensure reliable and trouble-free communications, the following is recommended:

- Twisted pair wires must be used for the communications wiring. Typical wire types are Belden p/n #8164, #9728 (4 pair) or equivalent. Use two pairs for the data and use one of the wires from an extra pair for the signal common. The signal common should *not* be connected to ground. Connect the overall cable shield to ground in one location only.
- The communication and DC power wiring should be routed or kept separate from any high voltage field wiring.

Communications Wiring

A complete data link connection at each Optomux unit (except the last in a string) consists of 10 wires: two twisted pairs (4 wires) and a common coming from the computer or previous Optomux unit, and two twisted pairs and a common going to the next Optomux unit. Use 4-pair cable with one of the wires from a pair for the signal common. One pair will be unused.

Host to First Optomux Unit

The following figures show two possible connections from the host to the first Optomux unit on the serial link. A suggested color code is shown to help avoid wiring errors.

DRAFT

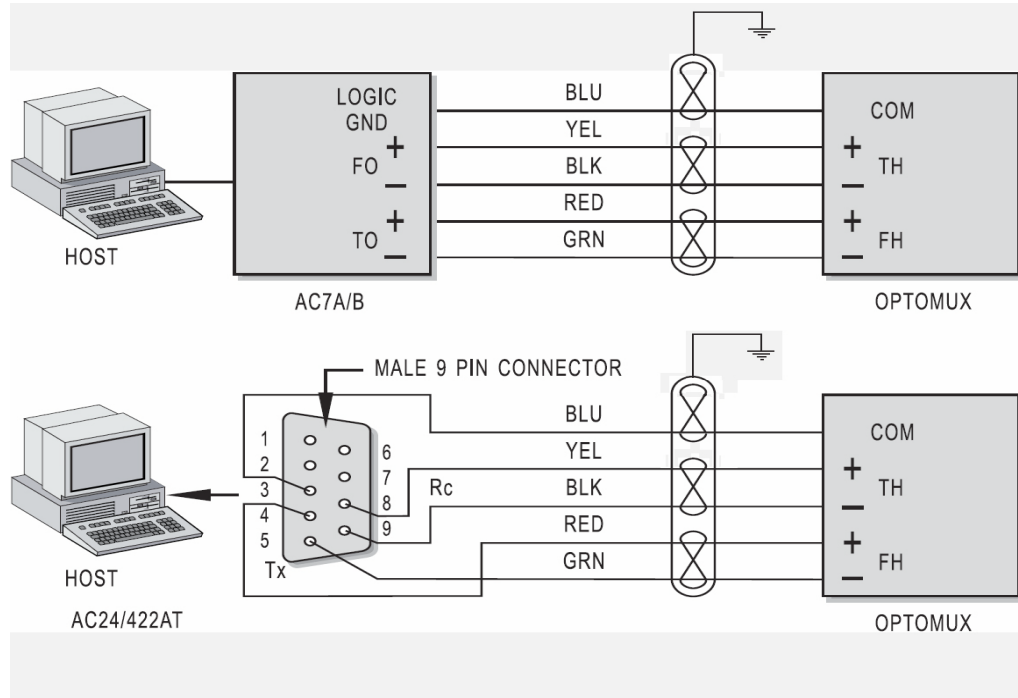
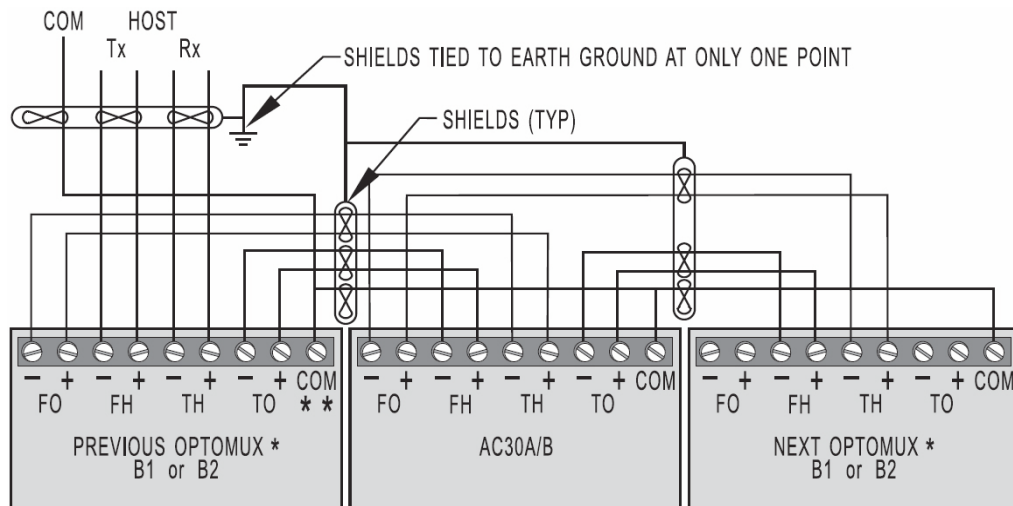

Figure 2-1: Communication Wiring, Host to Optomux Unit

Unit to Unit

The following figure shows the connection between adjacent Optomux units on the serial link. The Optomux unit at the end of the data link has only 5 wires — “To Host,” “From Host,” and common.

HINT: Always think of the previous Optomux units as the host.



* B2 COMMUNICATION CONNECTIONS ARE MADE TO THE RACK (PB4AH, PA8AH OR PB16AH), NOT TO THE BRAIN BOARD.

** DO NOT CONNECT ANY "COM" POINT TO EARTH GROUND.

Figure 2-2: Optomux Unit to Optomux Unit Communications Wiring

Installing Digital I/O Modules

CAUTION: Be sure that all Optomux unit power and power to the controlled devices is removed before installing or removing I/O modules. Each position on a digital mounting rack can accept either input or output modules. Install the color-coded I/O modules on the IO mounting rack by inserting the module pins in the sockets on the rack. Secure the modules with the captive Phillips-head screw.

Each power I/O module is connected to two barrier strip terminals on the I/O mounting rack. When connecting DC loads or input, the lower-numbered terminal is always more positive.

For detailed information concerning module specifications and wiring, refer to the module data sheets. Digital Optomux units only accept modules with 5-volt logic (for example, IDC5).

Each digital I/O mounting rack is supplied with an individual 5-amp fuse for each module position. The fuse is installed in a pair of sockets and may be removed with needle-nose pliers.

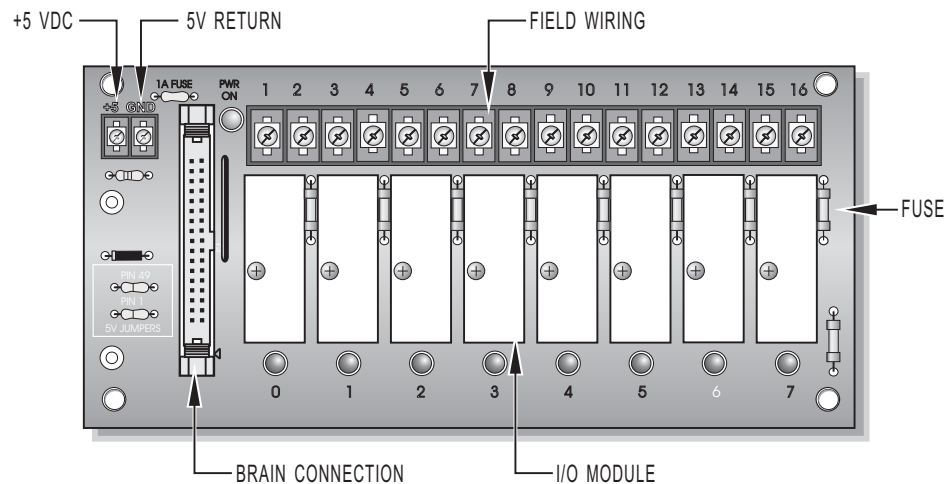

Figure 2-3: Digital Mounting Rack

Installing Analog I/O Modules

CAUTION: Be sure that all Optomux unit power and power to the controlled devices is removed before installing or removing I/O modules. Installing or removing modules with power applied can destroy the module.

Each position on an analog mounting rack can accept either an input or an output module. Install the I/O module that performs the required function. Secure the module with the captive Phillips-head screw. Refer to the module's data sheet for detailed specifications and wiring diagrams for each analog I/O module.

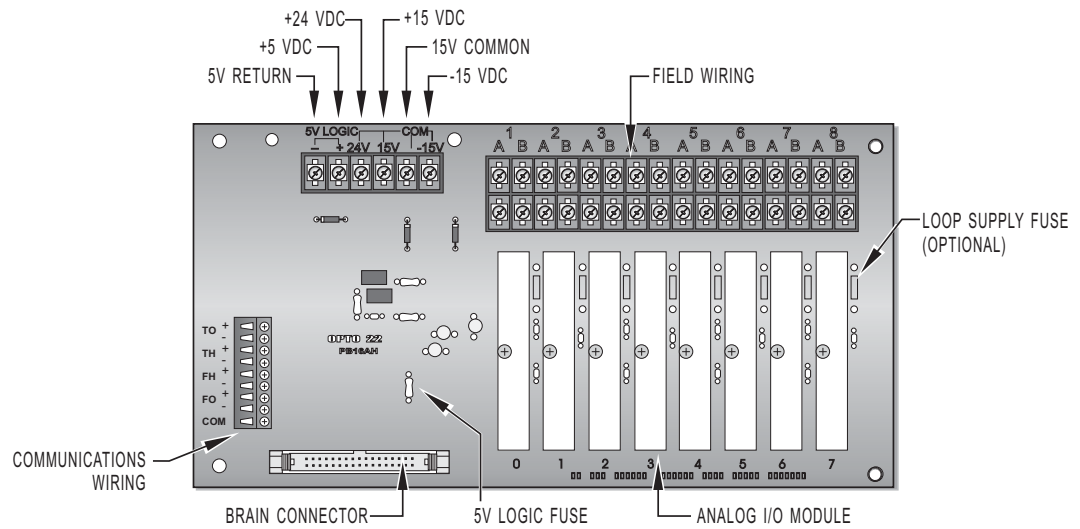

Figure 2-4: Analog Mounting Rack

DRAFT

Power Requirements

DC power must be provided to each Optomux unit. All B1 and B2 boards require +5 volts DC (± 1 VDC) at 0.5 amps.)

B2 analog units also require +15VDC and -15 VDC (± 25 VDC). The amount of power required is dependent upon the type and number of analog I/O modules that are plugged into the unit. The B2 requires +15 and -15 volts at 10 milliamps. Power requirements for analog modules are included in the module specifications. To determine what size power supply is needed, add the requirements for each module to the 10 milliamps required by the Optomux mounting rack.

Analog racks also provide terminals for a separate +24 volt supply to be used when powering a 4 - 20 mA loop using 4 - 20 mA analog I/O modules. For this type of application, the +24 volt supply is required in addition to the supplies mentioned above. Refer to the module's data sheet for information on wiring AD3 and DA3 modules with a loop supply.

The current requirements given for the output modules are only for the modules themselves. Load requirements must be added to these to determine total power supply requirements.

Although it is possible to distribute DC from a common power supply to several locations, better noise immunity is obtained by having separate power supplies at each physical location where an Optomux unit is installed.

A +5 VDC power supply option can be used to provide power to digital Optomux units. The power supply attaches to the I/O mounting rack beneath the removable brain board portion of the Optomux unit.

Connecting the Power Supply

Connect the 5-volt power to the barrier strip connectors marked "+ 5V" and "GND" on the mounting rack. If the + 5 volt supply is to be used by more than one Optomux unit or other devices, make sure there is 5 VDC ($\pm .1$ V) at each set of terminals on each rack. The communications wiring and the +5-volt and ± 15 volt wires should be routed away from any high-voltage field wires. There should only be one "earth" ground connection per network, typically connected at the host site. If the "earth" ground connection is at the host site, make sure none of the supplies is connected to "earth" ground. This method of grounding prevents ground loop problems due to offset voltages appearing between multiple ground points.

If an Opto 22 PBSA/B/C power supply is used with the digital racks, the + 5 VDC logic connection is made by the supply when it is screwed to the rack. In this case, the only connection to be made is the 120 VAC (220 VAC or 10-28 VDC depending on supply type) connection to the PBSA (PBSB or PBSC) supply.

Separate or combined + and - 15 VDC (± 25 VDC) supplies can be used to provide power to analog I/O modules. If using combined supplies, make sure that the 5 VDC RETURN line is separate from the 15-volt COMMON line. Otherwise, the isolation of the analog modules will be defeated.

CAUTION: Check polarities of all power supply connections before applying power to the Optomux unit. Incorrect polarity may cause damage to the unit.

DRAFT

Use a consistent color code from power supply to all Optomux units to prevent wiring errors. Size 18 AWG is recommended for power supply wiring. Optomux demo equipment uses the following colors:

Red	+5 Volts
Black	GND
Blue	+15 Volts
Yellow	-15 Volts
Brown	GND

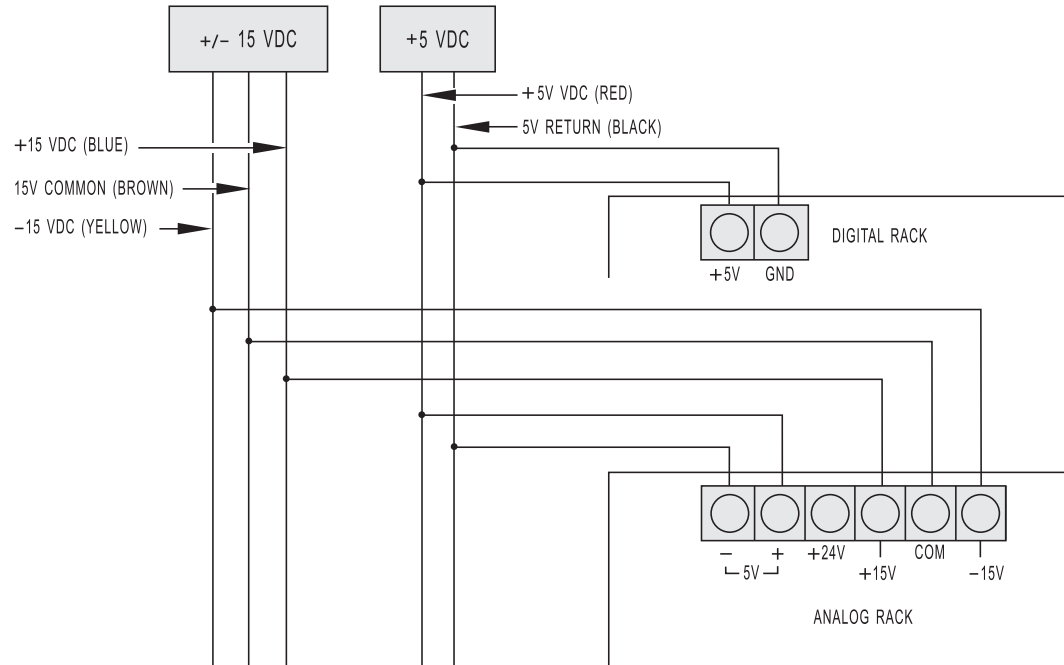

Figure 2-5: Power Supply Wiring

CAUTION: If brain boards are powered up and serial lines are left floating or are connected to RS-485 adapter card without proper biasing, the RX and TX LED lights may float to an unknown state. This may cause confusion as to the actual state of the communication lines and the proper operation of the brain board. We recommend checking to make sure that the communication lines have the proper biasing and termination resistors installed at the two ends of the RS-485 network.

DRAFT

Third-Party Power Supply Vendors

The following is a list of a few of the many power supply vendors:

COMPUTER PRODUCTS INC.

Power Conversion Group
2900 Gateway Dr.
Pompano Beach, FL 33069
(305) 974-5500

ELPAC POWER SYSTEMS

3131 S. Standard Ave.
Santa Ana, CA 92705
(714) 979-4440

POWER-ONE

740 Calle Plano
Camarillo, CA 93010
(805) 987-8741

POWER GENERAL

152 Will Drive
P.O. Box 189
Canton, MA 02021
(617) 828-6216

SOLA

1717 Busse Hwy.
Elk Grove Village, IL 60007
(312) 439-2800

NOTE: When specifying power supplies for powering Optomux analog units, some manufacturer's triple supplies have the +5 volts and the ± 15 volts commons connected, thereby defeating the isolation. To ensure complete isolation, use separate power supplies for the +5 volts and the ± 15 volts.

DRAFT

Brain Board Mounting

The brain board mates with the header connector on the rack. The orientation of the digital brain board (B1) should be such that the brain board extends away from the rack. The orientation of the analog brain board (B2) is such that the brain board covers up the communications and power wiring on the analog rack when it is plugged in.

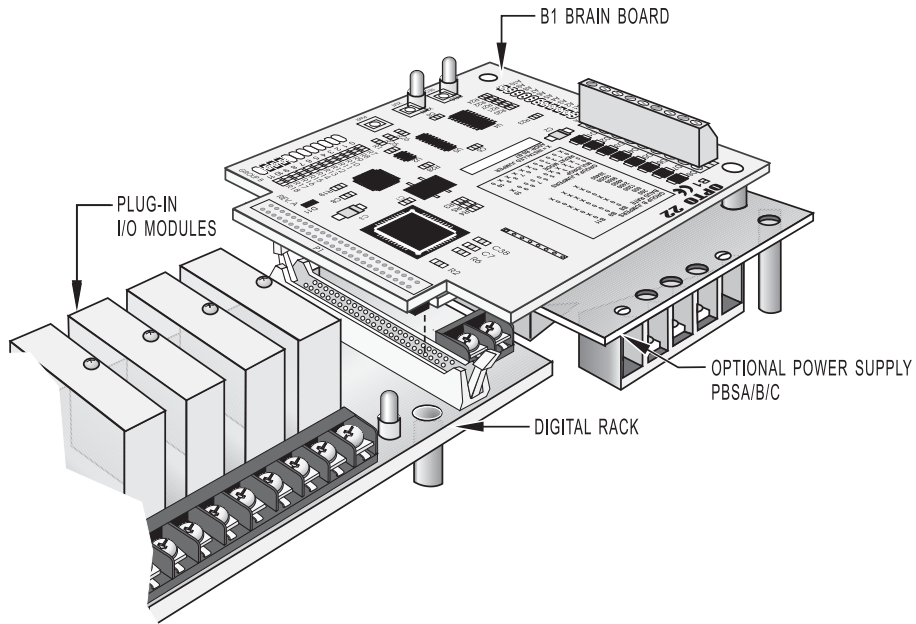

Figure 2-6: B1 Brain Board with Digital Mounting Rack

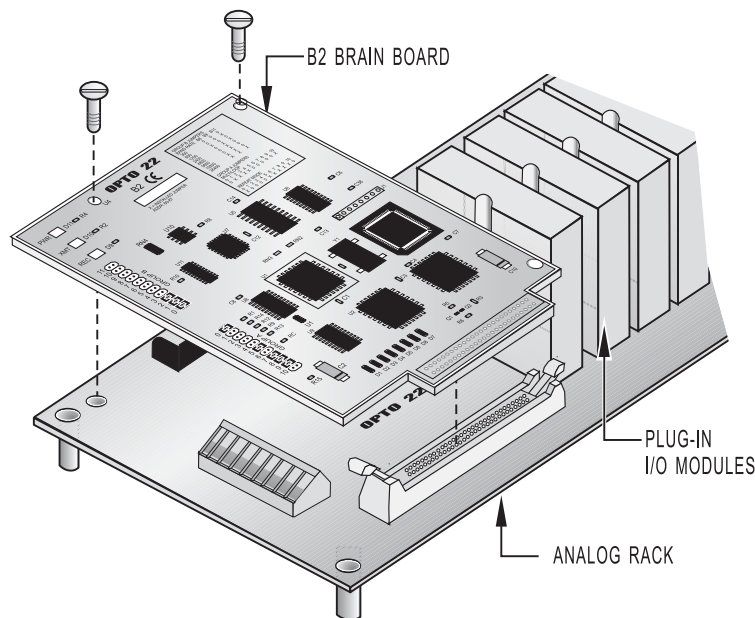

Figure 2-7: B2 Brain Board and Rack Assembly

DRAFT

Selecting the Jumpers

TIP: Use the "OptoScan" utility as an aid in setting jumpers.

There are two groups of jumpers located on each B1 or B2 brain board. The jumpers are labeled Group A and Group B.

Group A Jumpers

These jumpers route wiring for repeat-mode or multidrop communications and also provide the proper termination and biasing of the RS-422/485 network. All Optomux units on the same network should be configured for either multidrop or repeat mode, but not both.

For multidrop operation, verify that the jumpers in group A are installed as follows:

X = INSTALLED

:	X	X	X	X	:	:	:	:	:	X
0	1	2	3	4	5	6	7	8	9	10

Install jumper A0 and A6 if the Optomux unit is the last unit in the serial data link.

For repeat mode settings, all Optomux bus should be jumpered as follows:

X	:	:	:	:	X	X	X	X	X	:
0	1	2	3	4	5	6	7	8	9	10

Group B Jumpers

This group of jumpers selects the Optomux address and baud rate. Each Optomux unit on the same link must have a unique address (different from all others). All units on the same network should be set for the same baud rate.

The following information is required to set the jumpers on a single Optomux unit.

Optomux Address (0 - 255) _____

What is serial baud rate? _____

(300; 1,200; 9,600; 19.2K; 38.4K)

Multidrop or Repeat mode _____

DRAFT

Baud Rate Selection

Jumpers B8, B9, and B11 select the baud rate. Possible configurations are shown below.

Table 2-1: Baud Rate Jumper Settings

Baud Rate	B8	B9	B11
300	Not Installed	Not Installed	Not Installed
600	Not Installed	Not Installed	Installed
1200	Installed	Not Installed	Not Installed
2400	Installed	Not Installed	Installed
4800	Not Installed	Installed	Installed
9600	Not Installed	Installed	Not Installed
19200	Installed	Installed	Not Installed
38400	Installed	Installed	Installed

Protocol Selection

Jumper B10 selects between 2-pass and 4-pass communications protocol. The 2-pass protocol is the recommended protocol because it provides faster and more efficient communications. The 4-pass protocol is mainly for use as a troubleshooting aid. When jumper B10 is installed, 2-pass protocol is selected. The unit can be put into a 4-pass mode by removing the B10 jumper or using the Optomux software command "E."

Address Selection

Jumpers B0 through B7 select the Optomux address. Each Optomux unit on the same network must have a unique address (different from all the others). Addresses are arbitrary and do not need to be sequential (although they must be unique). The following table lists the possible addresses with corresponding jumper configurations. To use the table, find the address you wish to use (0 to 255). To the right of the address is the sequence of jumpers in the following order: B7, B6, B5, B4, B3, B2, B1, and B0.

DRAFT

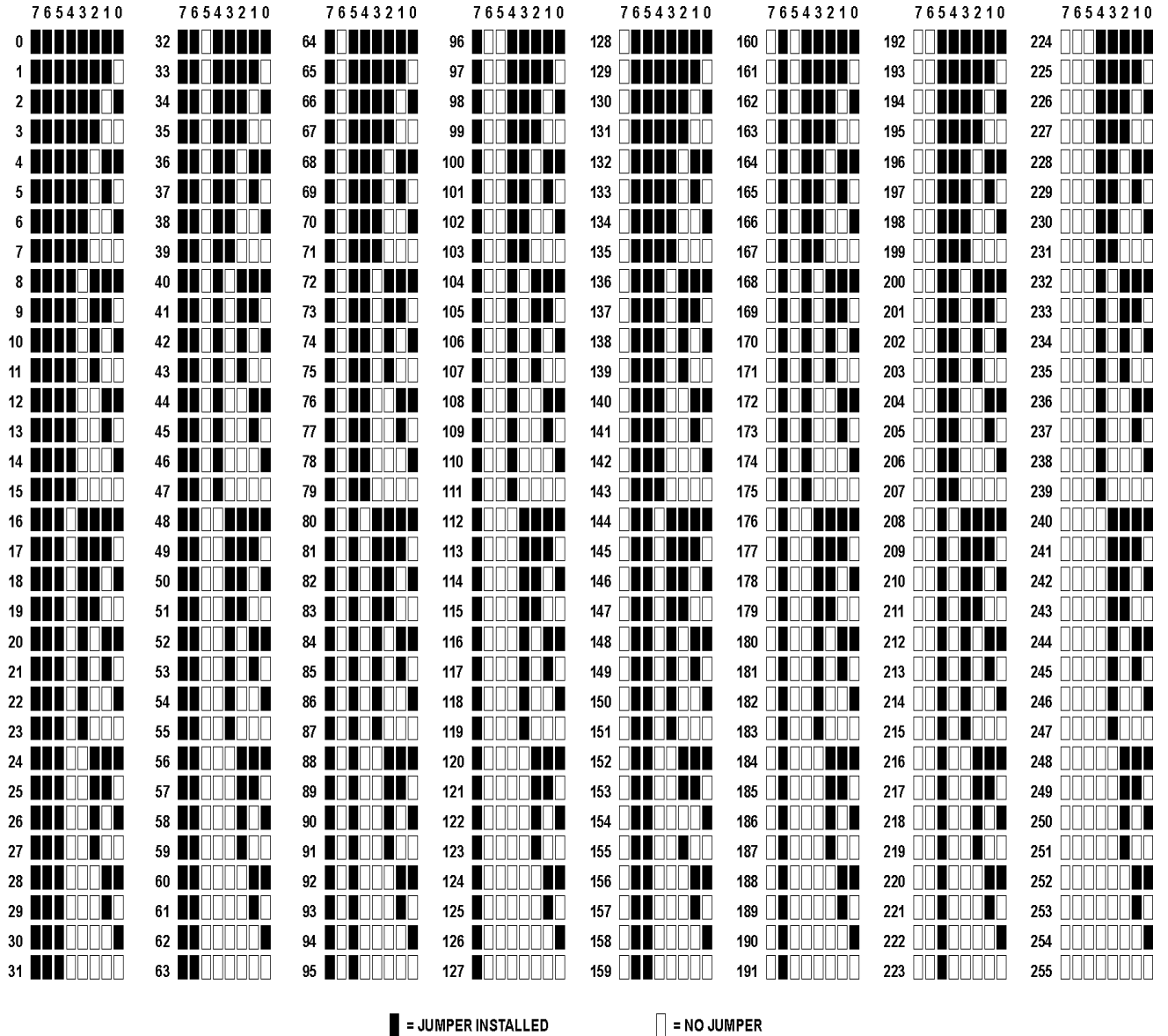

Figure 2-7: Jumper Addresses

Accessories

There are several accessories for the Optomux family, ranging from power supplies to adapter cards. Several are listed below. Please refer to the Opto 22 Web site (www.opto22.com) for detailed information on the following products.

Power Supplies

PBSA, PBSB, PBSC: The PBSx series of devices are 5 VDC power supplies that mount directly to digital I/O racks that have a header connector. The power supply mounting allows an Optomux digital brain board to be mounted on top of the supply, thereby saving panel space. The PBSA is for 120 VAC operation, the PBSB is for 240 VAC, and the PBSC is for 12/24 VDC operation.

Adapter Cards

AC7A, AC7B: This serial adapter card converts any full duplex RS-232 port to an RS-422/485 port, allowing any computer with a serial RS-232 port to communicate to an Optomux network. The AC7A is for 120 VAC operation and the AC7B is for 240 VAC operation.

AC8: This serial adapter card converts a half duplex RS-232 serial port to a full duplex RS-422/485 port. The adapter is used for connecting half duplex radio modems to the Optomux network.

AC30: This adapter card is an RS-422/485 repeater, used to extend the 5,000 foot limit of an Optomux serial multidrop network.

AC31: This adapter is an intelligent network interface for the Optomux network. It allows serial devices (RS-232 or RS-422/485) that are not addressable to reside on the serial Optomux network as slaves to a host computer. Devices may include printers, terminals, barcode readers, counters, motion controllers, etc.

PCI-AC48: The PCI-AC48 is an isolated, high-speed adapter card designed to link RS-485 serial devices with computers using the Peripheral Component Interconnect (PCI) bus. This adapter card is ideal for customers who have been using Opto 22's AC37 adapter card, but must upgrade to a newer computer that uses the PCI bus instead of the ISA bus.

DRAFT

A: Surge Protection

Surge Protection For RS-422/485 Communication Links

For more information or for catalog requests, contact:

Phoenix Contact Inc.
P.O. Box 4100
Harrisburg, PA 17111-0100
E-mail: info@phoenixcon.com
Phone: (717) 944-1300
Fax: (717) 944-1625
Fax-on-demand: (800) 944-9901

DRAFT

DRAFT

B: Troubleshooting

Troubleshooting Questions and Answers

Q. I send a command to turn on output 5 of an Optomux unit at address 255, and output 4 goes on.

A. Module positions are numbered from 0 to 15. Therefore the fifth bit in the bitmask is for position labeled 4. Following are the bitmask values for each position:

Position	Bitmask
0	0001
1	0002
2	0004
3	0008
4	0010
5	0020
6	0040
7	0080
8	0100
9	0200
10	0400
11	0800
12	1000
13	2000
14	4000
15	8000

Q. I send a command to activate several outputs. The Optomux unit responds with no error, but none of my outputs come on.

A. If an output does not turn on, check the following:

- a.** Make sure you configured the outputs of the Optomux unit correctly. The unit defaults to all positions configured as inputs on power-up.
- b.** If power was lost at any time and returned, the unit will have lost its configuration. The unit will have reported a N00 error to the first command sent after the power-up to indicate that configuration was lost.
- c.** If using a digital Optomux unit, make sure you are using output modules with a 5 VDC logic voltage (OAC5, ODC5, etc.). Sometimes modules with a 15 VDC or 24 VDC logic voltage (ODC15, OAC24, etc.) are inserted by mistake. The LED may turn on or be dim with the 15 VDC and 24 VDC modules, but there will be no output on the field side.
- d.** If the output LED is on, but the load does not turn on, check the field voltage and wiring. Also, the load may not draw enough current to meet the minimum current requirements of OAC5 modules (20 mA).

Q. I send a command message to an Optomux unit at address 0, and I get no response. However, the Optomux's REC light flashes.

A. The receive lights on all the Optomux boards wired in a multidrop mode should light whenever a command is sent. Only the unit at the address that matches the command message address should respond. When an Optomux unit responds, the XMT (transmit) light will flash. At high baud rates, and for messages with only a short response ("A" only), the flash will be so brief it may be missed visually.

If the host receives no response, and no flash of the XMT light is visible at the slowest baud rate (300), then check the following:

- a.** Make sure the address in the command message matches the Optomux address. Check the jumpers. A common mistake is a reversal of jumpers. All address jumpers (B0 through B7) installed are address 0, and all address jumpers (B0 through B7) removed corresponds to address 255.
- b.** Make sure the baud rate is correct between the host and the Optomux unit. All Optomux units on the same link should be configured to the same baud rate.
- c.** Make sure you have a solid +5 volts powering the Optomux unit. If the voltage is too low, the RCV light may flash, but the unit will not be able to respond. Measure the voltage at the unit's power terminals — not at the power supply.
- d.** Check to make sure the communications link is wired with the correct polarity and that the A group of jumpers is configured correctly.

Q. When I read position 3 of an Optomux analog board, I receive a 0000, which converts to a decimal -4,096 value when I subtract the 1,000 hex offset.

A. A -4,096 decimal reading may indicate one of the following:

- a.** You are reading a module position that has no input module installed.
- b.** You are reading a thermocouple module that has no thermocouple installed, or the thermocouple probe is open.
- c.** An ICTD module has the ICTD wired in reverse.
- d.** A 4–20 mA module is wired with reverse polarity.
- e.** The field connections are made to the wrong terminals. Field connections vary with each module. Refer to the module's data sheet for information on wiring each specific module. In general, field connections made to the terminals on the rack are made to the terminals

DRAFT

labeled UPPER (closest to module), and if the module has terminals on the top of the module, connections would be made there. Analog racks have the terminal channels labeled from 1 to 4 (or 16). These channels correspond to module positions 0 to 3 (or 15) respectively.

- f. If all inputs on that board have the same -4,096 reading, then check to make sure the board has +15 and -15 VDC at the corresponding terminals (with reference to the terminal that is marked COMMON).

Q. I receive a large number of checksum errors (N02) when I send commands to an Optomux unit.

A. Make sure that you are using twisted pair cable. The RS-422/485 network is only reliable when the communications cable is twisted (+ and - lines of EACH pair twisted together) with at least 1/2 twist per inch. Sometimes, the wire is twisted but one of the connections of a pair is actually used as the mate to the opposite pair (- of one pair used as - of opposite pair). This cross-twist condition is usually due to jacketed twisted pair cables, which have a wire of each pair with the same color code. In this case, strip the jacket back far enough to properly identify the individual pairs.

You should also check the Group A jumpers to make sure the termination and bias jumpers are correctly installed.

DRAFT

DRAFT