

OPTOEMU SENSOR (ENERGY MONITORING UNIT)

Features

- > Monitor real-time energy usage from utility meters, electrical panels, subpanels, and equipment
- > View detailed real-time and historical energy usage data online through your chosen software service
- > Send data to a SNAP PAC System, systems using Modbus/TCP or OPC, or SQL databases
- > Communicate over standard 10/100 Mbps Ethernet or wireless LAN (802.11a, b, or g), or both at once



OptoEMU Sensor 3V

DESCRIPTION

*** NOTE: OPTOEMU-SNR-3V is obsolete and no longer available when current stock is depleted. OPTOEMU-PT600 is obsolete and not longer available. ***

The OptoEMU Sensor™ Energy Monitoring Unit monitors the electrical energy used in your facility and then delivers that data to online software applications or control systems. The OptoEMU Sensor gives you the detailed, real-time data you need to analyze energy consumption and reduce energy costs.

Why Monitor Energy?

Traditionally, the cost of energy has been considered an overhead cost. Utility bills show few details about when and how electricity was used, and they arrive long after the energy was consumed.

However, new energy pricing structures are changing traditional ways of looking at energy costs. Increasingly, commercial and industrial businesses are finding that they can significantly reduce energy costs by managing energy in the same way as other business costs such as people, assets, and inventory. Energy management represents significant opportunities to improve the bottom line.

Reducing energy costs does not require complex or expensive technology; it requires basic information. That information starts with gathering detailed, real-time data through the OptoEMU Sensor.

Viewing Energy Data

Real-time and historical energy data gathered by the OptoEMU Sensor is viewed online through a secure software service. You choose the service that's best for your business.

The OptoEMU Sensor sends energy data directly to the service you choose, and you can view the data from any authorized computer or mobile device in accordance with the service you purchase.

Using Energy Data in Other Systems

Energy data from the OptoEMU Sensor can also be sent to other systems for use there. Sensor data can be incorporated in a PAC Control strategy, a PAC Display HMI, and control systems that communicate through Modbus®/TCP or OPC.

In addition, energy data can be sent to common SQL databases such as MySQL® and SQL Server®.

Using Sensor data in these other systems, you can manage energy usage and costs in detail. For more information on using energy data in other systems, see form 1958, the *OptoEMU Sensor Communication Guide*.

Connecting to Electrical Devices

The OptoEMU Sensor can connect to a variety of metering devices that emit pulses. It can connect to Modbus devices over serial or Ethernet. And it can also connect directly to electrical circuits using current transformers (CTs) with a 0.333 VAC secondary.

Part Numbers

| Part | Description |
|---|--|
| OPTOEMU-SNR-3V [OBSOLETE and available until stock is depleted] | [OBSOLETE and available until stock is depleted] Energy monitoring unit for electrical panels, machines, and devices, Wired+Wireless™ |
| CBL-PWR-120VUS | Temporary power cable accessory for initial IP address configuration, North America |
| CBL-PWR-240VEU | Temporary power cable accessory for initial IP address configuration, Europe |
| OPTOEMU-PT600 [OBSOLETE] | [OBSOLETE] Auxiliary box for OptoEMU Sensor, with stepdown transformer and fusible disconnect |

Connecting to pulse, serial, and Ethernet inputs

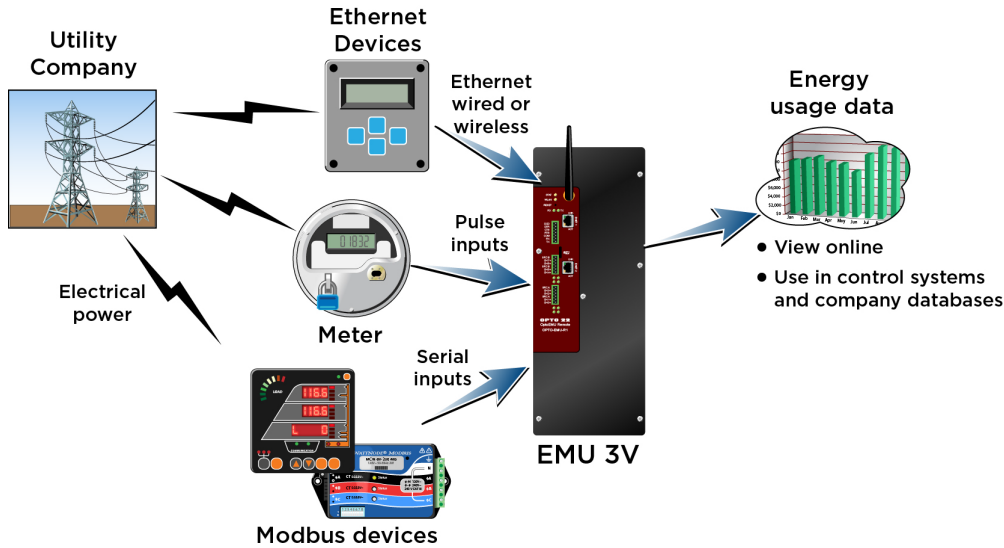

Connecting directly to a panel

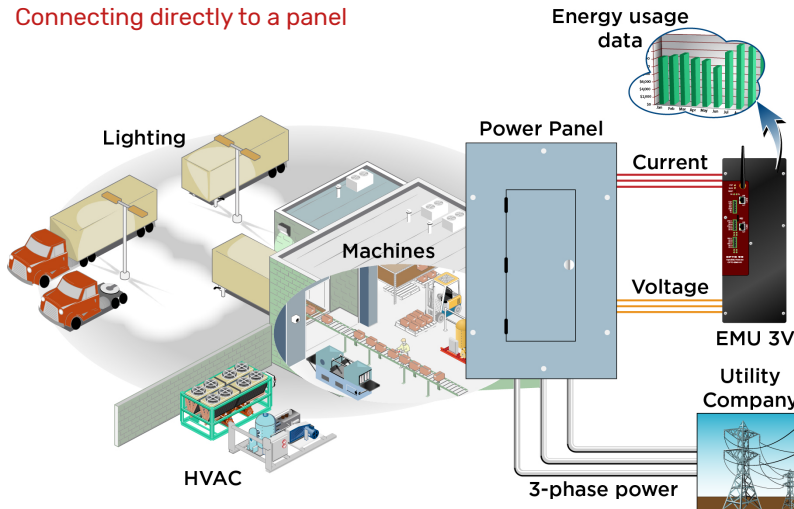

The Sensor can monitor energy devices in all ways, simultaneously:

- **Pulse**—The Sensor can monitor up to four electrical devices that emit a pulse output, such as a utility meter or submeter.
- **Ethernet**—The Sensor monitors Modbus/TCP energy devices that connect over an Ethernet network.
- **Serial**—The Sensor monitors Modbus energy devices that connect over a serial network. The serial interface on the unit is software configurable for RS-232 or RS-485.

A total of 64 Modbus data items (over Ethernet and serial) can be monitored.

- **Direct**—Using suitable current transformers (CTs) with a 0.333 VAC secondary, the Sensor can monitor voltage and current directly from the main power load panel on a building or facility. It can also monitor loads from individual subpanels or electrical equipment such as chillers, boilers, compressors, elevators, and air handling units.

One Sensor can connect to one 3-phase electrical panel or device or to three single-phase panels or devices. The Sensor measures line-to-neutral voltage and is suitable for up to 600 volt systems (346 VAC wye).

If you need a fusible disconnect or plan to power the Sensor from a monitored panel or device with a voltage higher than 240 VAC, also purchase the OPTOEMU-PT600 auxiliary box, which contains a transformer and fusible disconnect.

Configuration

The Sensor includes an easy-to-use utility program for assigning an IP address for communication on your network, configuring the monitored devices, and entering the necessary information to connect to the software service.

A temporary power cable accessory is available, if needed, for assigning the IP address before installation. (See “Part Numbers” on page 1.)

Communication

The OptoEMU Sensor uses standard computer networks and protocols to send data to the online software service, which displays energy use to authorized viewers over the Internet.

The OptoEMU Sensor communicates with these services over a standard 10/100 Mbps Ethernet network or over an 802.11a, b, or g wireless LAN (local area network). With wired Ethernet network interfaces plus an independent wireless interface, the unit gives you the flexibility to monitor devices in hard-to-reach areas and to set up networking suited to your business.

Security on the wireless LAN includes 802.11i WPA2/AES, currently considered the best wireless security, plus the older WPA security standard for backwards compatibility.

Data Storage

The OptoEMU Sensor can store data internally. If communication with the software service is lost, the unit stores data for delivery when communication is restored.

Mounting and Wiring

If the OptoEMU Sensor is monitoring voltage and current directly from a panel or device, it should be mounted right next to it. Power for the unit is normally supplied by a 120 VAC or 240 VAC connection. If you need to power the Sensor from a panel or device with higher voltage, also purchase the auxiliary box with transformer and fusible disconnect (part number OPTOEMU-PT600).

WARNING: Follow all installation instructions in the [OptoEMU Sensor User's Guide](#) to avoid serious or fatal injury or severe damage to equipment. All electrical wiring to the unit must be done by a qualified electrician.

Data In and Data Out: OptoEMU Sensor 3V

OptoEMU Sensor 3V monitors:

- Pulsed outputs from pulsing meter or submeter
- Energy devices that communicate over a serial network using the Modbus protocol
- Ethernet energy devices that communicate using Modbus/TCP
- Direct voltage and current from:
 - Main electrical panel
 - Electrical subpanels
 - Electrical equipment such as chillers, boilers, compressors, elevators, and air handling units (AHUs)



OptoEMU Sensor 3V provides data for:

- Online energy monitoring applications
- PAC Control strategies
- PAC Display HMIs
- OPC 2.0-compliant clients
- Standard databases (SQL Server, MySQL, Microsoft Access)
- Modbus/TCP systems
- Custom systems you've developed, for example using our .NET Toolkit

Wiring for Pulsed Inputs

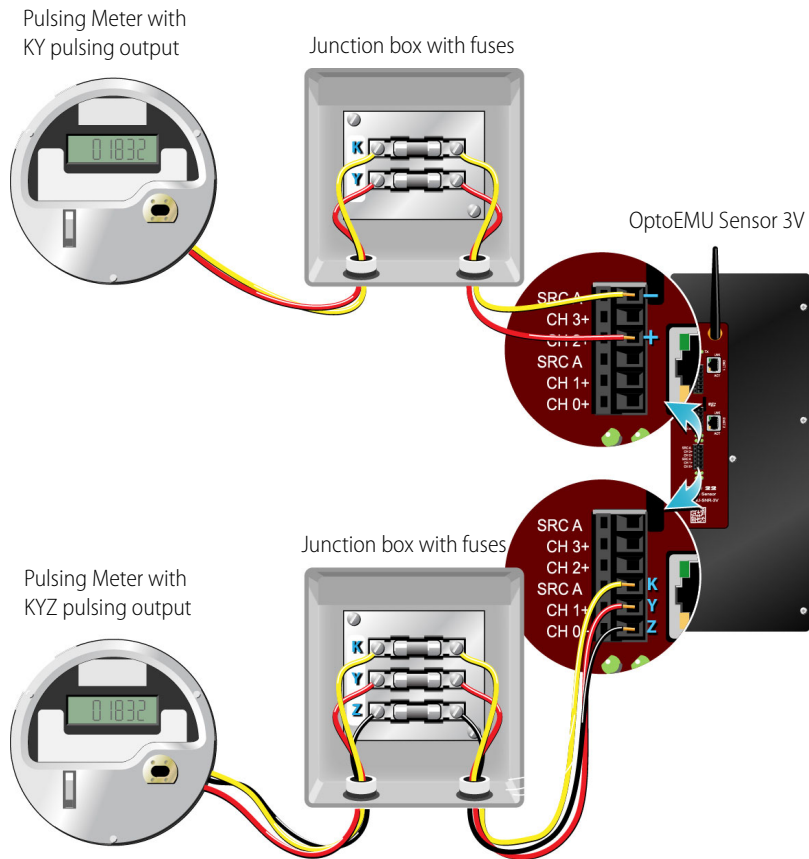

Use with either two-wire KY (Form A) or three-wire KYZ (Form C) pulsing devices.

Contact your utility company if connections are not immediately apparent.

Follow wiring instructions in the [OptoEMU Sensor User's Guide](#), form #1932.

NOTE: If this equipment is used in a manner not specified by Opto 22, the protection provided by the equipment may be impaired.

Wiring for Serial Ports

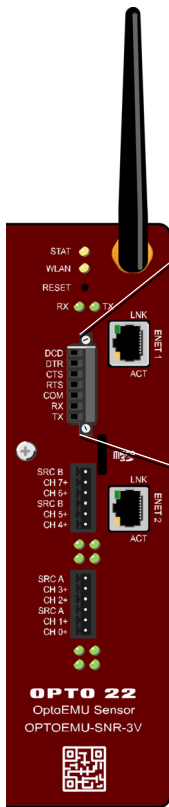

RS-232 and RS-485 Pinouts

| RS-232 | Signal Direction | RS-485 | Signal Direction |
|--------|------------------|--------------|------------------|
| DCD | In | -- | |
| DTR | Out | -- | |
| CTS | In | RX- (4 wire) | In |
| RTS | Out | RX+ (4 wire) | In |
| COM | | COM | |
| RX | In | TX/RX- | In/Out |
| TX | Out | TX/RX+ | In/Out |

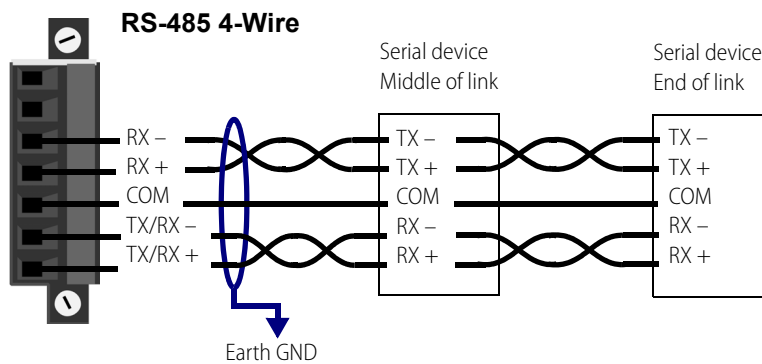
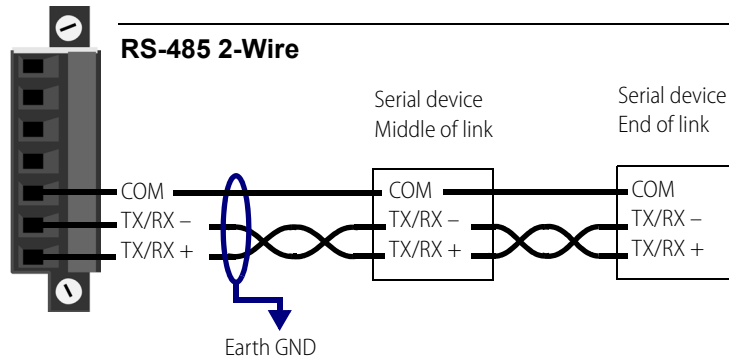

Direct Connection Using CTs

Follow wiring instructions in the *OptoEMU Sensor User's Guide*, form #1932.

UL requires CTs to be CAT III approved. Category III is for measurements performed in the building installation, for example circuit breakers, wiring, distribution boards, equipment for industrial use, etc.; see IEC 61010.

UL also requires that CTs be **UL Listed Energy Monitor Current Transformers**. Suitable CTs can be obtained from Sentran Corporation—for example, part numbers LN4F-300-333 (300 A, 1.25" window), LN3F-150-333 (150 A, 0.70" window), or LN2F-100-333 100 A, 0.40" window). See the manufacturer for other ranges and window sizes.



WARNING: DANGER. *Electrical hazard. Authorized personnel only.*

All electrical wiring to the unit must be done by a qualified electrician.

If this equipment is used in a manner not specified by Opto 22, the protection provided by the equipment may be impaired.

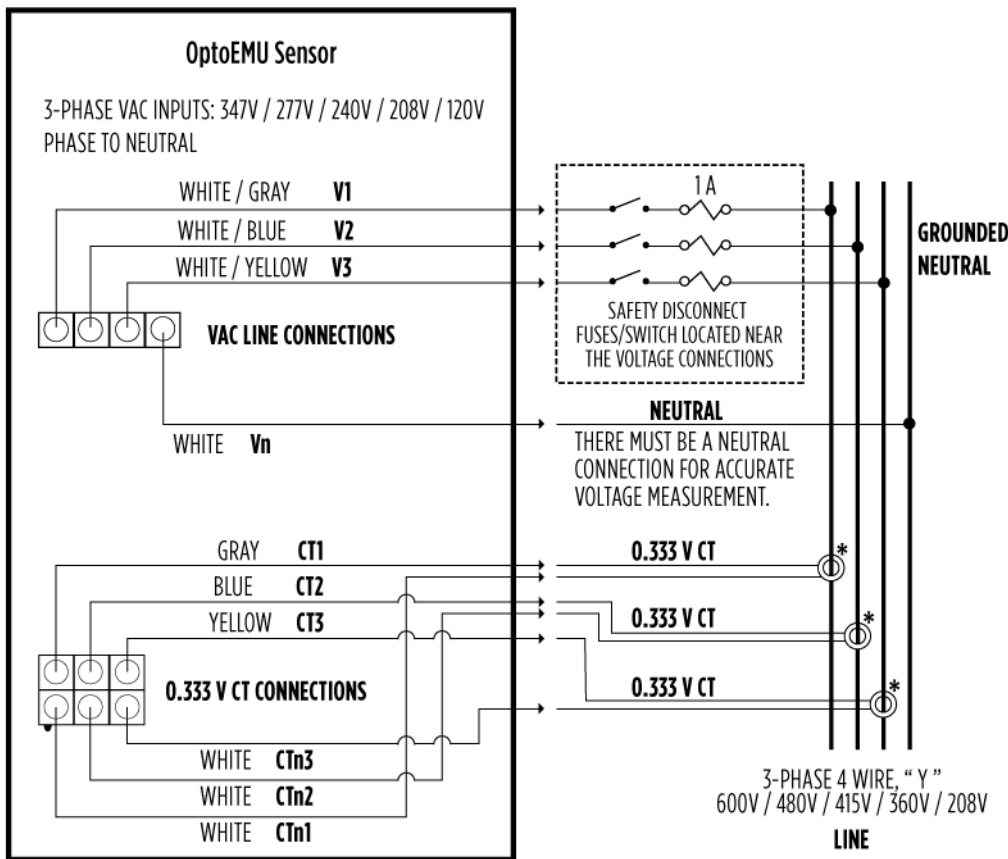

*ARRANGE ALL OF THE 0.333 V CTs THE SAME WAY ON THE LOAD CABLES AND CONNECT THE CT SIGNAL WIRES IDENTICALLY (LABELED OR COLORED) TO THE WHITE WIRES.

IF FEWER THAN 3 PHASES, CONNECT UNUSED CT AND VOLTAGE INPUTS TO THEIR RESPECTIVE NEUTRAL (WHITE WIRE)

CTs MUST BE CAT III APPROVED.

SPECIFICATIONS: OPTOEMU SENSOR

Overall Unit Specifications

NOTE: OPTOEMU-SNR-3V is OBSOLETE and available until stock is depleted.

| | | |
|--|---|---|
| Power Requirements (without auxiliary box) | 100–240 VAC, 47–63 Hz, 0.4 A maximum, 8 W | |
| Power Requirements (with auxiliary box) | 100–240 VAC (single phase) or 277–346 VAC (line to neutral from 480–600 VAC panels) | |
| Dimensions | 6.0"w x 13.5"h x 4.5"d (15.2 cm x 34.3 cm x 11.4 cm) | |
| Enclosure | Sturdy metal enclosure with standard knockouts for wiring | |
| Removable storage | MicroSD card slot (for future use) | |
| Backup battery | Rechargeable (recharges whenever the unit has power), 3-year power-off data retention | |
| Ethernet Communication (wired) | Two independent 10/100 Mbps Ethernet network interfaces (RJ-45 connectors), each with a separate IP address. | |
| Ethernet Communication (wireless) | Wireless LAN interface with separate IP address. | Frequency 802.11a: 5.180–5.240 GHz, 5.745–5.825 GHz |
| | Security: 802.11i: AES - Compatible with WPA2 Personal; TKIP - Compatible with WPA Personal. | Frequency 802.11b/g: 2.412–2.472 GHz, 2.484 GHz |
| | Roaming: Supported within an SSID (Service Set Identifier) only | Transmit Power: 5 dBm maximum Antenna Connector: Reverse polarity SMA (RP-SMA or RSMA) |
| Serial Communication | One serial port, software configurable for RS-232 (TX, RX, COM, DTR, DCD, RTS, CTS) or RS-485 (2-wire, 4-wire, optional termination, optional biasing). | |
| Indicators | Status of unit Wireless: WLAN activity Serial: Receiving, Transmitting Ethernet interfaces (2): Link, Activity Pulse inputs: On/Off status | |
| Other features | Real-time clock | |
| Operating Temperature | 0 to 60 °C (32 to 140° F) | |
| Storage Temperature | -25 to 85 °C (-13 to 185° F) | |
| Humidity | 0% to 95% relative humidity, non-condensing | |
| Agency Approvals* | UL, cUL, DFARS Wireless: U.S., FCC Part 15 Subpart C; Canada, IC RSS-210 | |
| Warranty | 30 months | |

(Specifications continue on following page.)

SPECIFICATIONS (CONTINUED)

Dry Contact Pulse Inputs

OptoEMU Sensor supplies 15 volts to each external dry contact switch and senses switch closure.

| | |
|---|---|
| Open Circuit Voltage (Switch Open) | 15 VDC typical (supplied by OptoEMU Sensor) |
| Short Circuit Current (Switch Closed) | 7 milliamps nominal |
| Minimum Off Resistance | >20 K ohms |
| Maximum Allowable ON Resistance (Wire + Contact Resistance) | 500 ohms |
| Turn-on Time | 5 msec |
| Turn-off Time | 25 msec |
| Channel-to-channel Isolation | 8 channels isolated in groups of two |
| Input-to-output Isolation | 1500 V AC/DC |
| Minimum Pulse Width | >= 7 milliseconds |
| Maximum Frequency | <= 30 Hz |
| Status indicators | 1 LED per channel |

3-Phase Power Monitoring

| Voltage Inputs (each voltage channel) | |
|---------------------------------------|--|
| Input Range | 0 to 400 VAC RMS (line to neutral—347 V for a 600 V 3-phase system or 277 V for a 480 V 3-phase system) |
| Input Over Range | To 440 volts |
| Resolution | 10 mV |
| Accuracy (47 to 63 Hz) | ± 0.2 V plus ± 0.2% reading (at full scale = ±0.2 V + ±0.8 V = ±1.0 V) |
| RMS Integration Time/ Data Freshness | 1000 ms (synchronous with current measurement) |
| Input Resistance – Single Ended | 1 Megohm NOTE: Because both channels share the same reference terminal, polarity must be observed when connecting the current channel. |
| Maximum Input | 600 V non-operating |
| Current Inputs (each current channel) | |
| Input Range | 0 to 333 mV AC input from current transducer |
| Input Over Range | To 416 mV AC |
| Input Overload | 5 VAC continuous, non-operating |
| Resolution | 15.1 µV AC |
| Accuracy (47 to 63 Hz) | ± 266 microvolts plus 0.2% of reading (at full scale = 266 µV + 667 µV = 933 µV = 0.28%) |
| RMS Integration Time/ Data Freshness | 1000 ms (synchronous with voltage measurement) |
| Input Resistance – Single Ended | 500 K Ohms NOTE: Because both channels share the same reference terminal, polarity must be observed when connecting the voltage channel. |
| Maximum Input | 5 VAC continuous, non-operating |

OPTOEMU-PT600 AUXILIARY BOX (OBSOLETE OPTIONAL ACCESSORY)

Use the OPTOEMU-PT600 **[Obsolete]** auxiliary box only if you need a fusible disconnect, or if you are powering the OptoEMU Sensor from a monitored panel or device with a voltage higher than 240 VAC.

Wiring diagram appears on the following page. For complete wiring instructions, see the [OptoEMU Sensor User's Guide](#) (form 1932).

Specifications

OPTOEMU-PT600 is OBSOLETE and no longer available.

| | |
|---------------------|---|
| Input voltage range | 220–600 VAC line-to-line |
| Output voltage | 110–240 VAC (power for OptoEMU-SNR-3V) |
| Fuses | 1 amp, class CC, 600 VAC (Edison part number HCLR1) |
| Dimensions | 6.0" w x 13.5" h x 4.5" d (15.2 cm x 34.3 cm x 11.4 cm) |
| Enclosure | Sturdy metal enclosure with standard knockouts for wiring |
| Agency Approvals* | CE, RoHS, DFARS |
| Warranty | 30 months |



WARNING: DANGER. *Electrical hazard. Authorized personnel only.*

All electrical wiring to the unit must be done by a qualified electrician.

WARNING! *Disconnect power upstream from unit when wiring or servicing to avoid potential shock hazard. This unit must be on its own circuit breaker.*

If the equipment is used in a manner not specified by the manufacturer, the protection provided by the equipment may be impaired.

Wiring Diagram—OPTOEMU-PT600 [OBSOLETE]

See warnings on page 9.

Follow wiring instructions in the *OptoEMU Sensor User's Guide*, form #1932.

UL requires CTs to be CAT III approved. Category III is for measurements performed in the building installation, for example circuit breakers, wiring, distribution boards, equipment for industrial use, etc.; see IEC 61010.

UL also requires that CTs be **UL Listed Energy Monitor Current Transformers**. Suitable CTs can be obtained from Sentran Corporation—for example, part numbers LN4F-300-333 (300 A, 1.25" window), LN3F-150-333 (150 A, 0.70" window), or LN2F-100-333 100 A, 0.40" window). See the manufacturer for other ranges and window sizes.

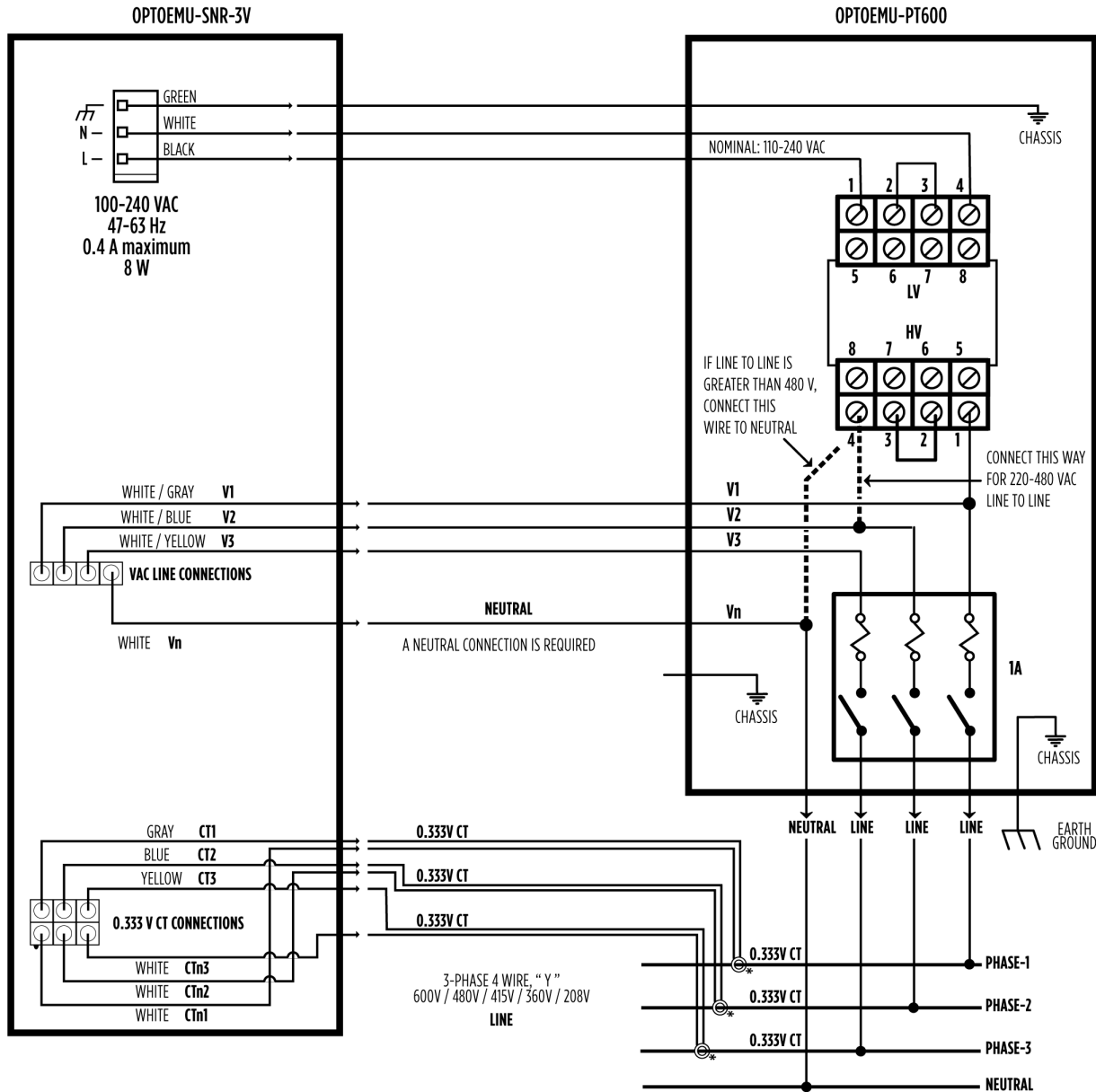

*ARRANGE ALL OF THE 0.333 V CTs THE SAME WAY ON THE LOAD CABLES AND CONNECT THE CT SIGNAL WIRES IDENTICALLY (LABELED OR COLORED) TO THE WHITE WIRES.
IF FEWER THAN 3 PHASES, CONNECT UNUSED CT AND VOLTAGE INPUTS TO THEIR RESPECTIVE NEUTRAL (WHITE WIRE).
CTS MUST BE CAT III APPROVED.

Dimensional Diagram—OPTOEMU-SNR-3V [OBSOLETE and available until stock is depleted]

